

Hydraulic Swing Clamp

- | | |
|-----------|-------------|
| Model LHA | Model LT/LG |
| Model LHC | Model TLA-2 |
| Model LHS | Model TLA-1 |
| Model LHW | Model TLB-2 |



High Rigidity • Long Life • High Accuracy

High Speed • High Rigidity • Swing Completion Position Repeatability $\pm 0.5^\circ$ ($\pm 0.75^\circ$ only for LHS)

Action Description

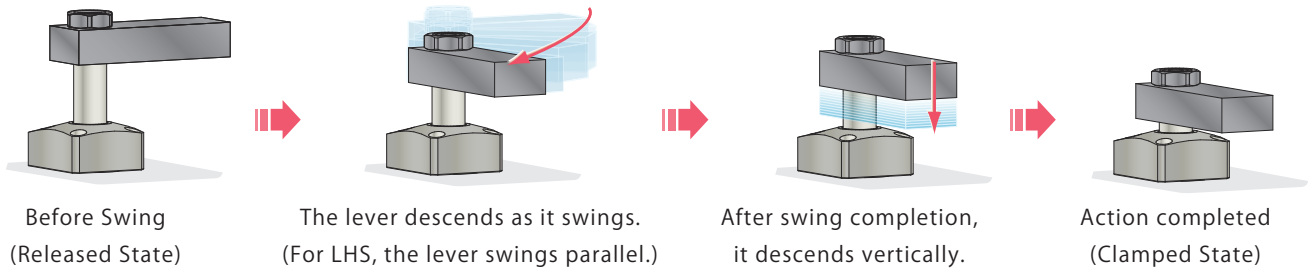

Application Examples

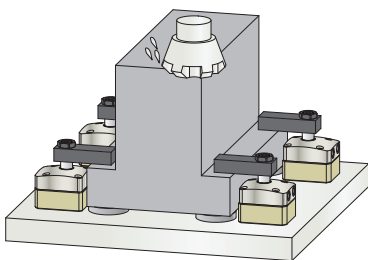

Machining

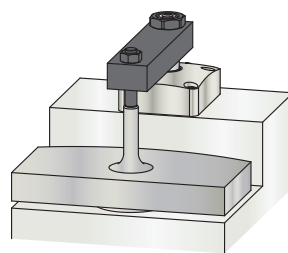

For the applications which require clamp position repeatability

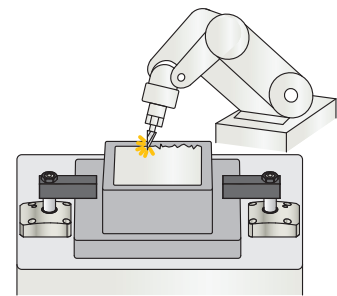

Deburring

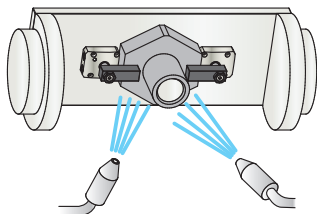

Cleaning

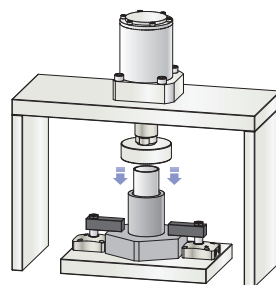

Press Fitting

New Products

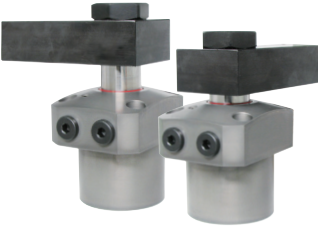

Compact Swing Clamp

Model LHC

Compact swing clamps for small footprint fixtures designed with minimum required stroke.

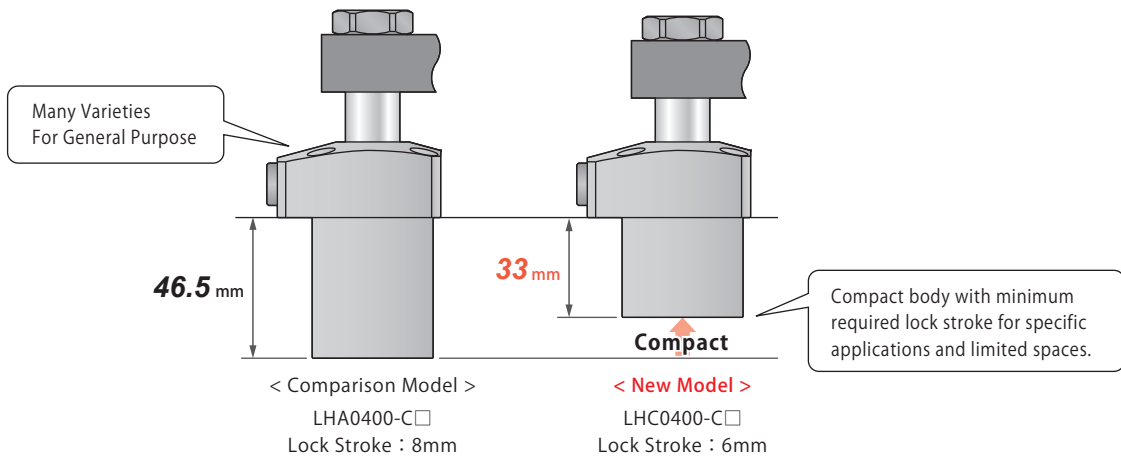

Air Sensing Swing Clamp

Model LHW

Clamp-unclamp confirmation with built-in air catch sensor for smaller footprint fixtures.

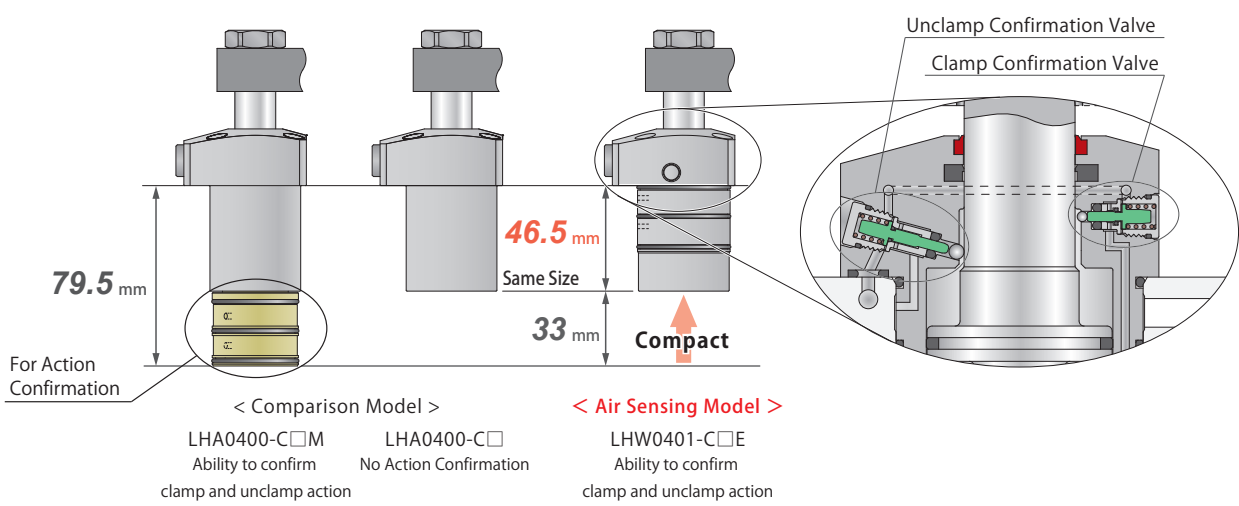

High-Power Swing Clamp Hydraulic Double Action

Model LHE

2 sizes smaller with equivalent clamping force. Mechanical lock and hydraulic pressure allow for strong clamping and holding force. Refer to P. 13 for further information.

- High-Power Series
- Pneumatic Series
- Hydraulic Series**
- Valve / Coupler Hydraulic Unit
- Manual Operation Accessories
- Cautions / Others

- Hole Clamp
 - SFA
 - SFC

- Swing Clamp**
 - LHA
 - LHC
 - LHS
 - LHW
 - LT/LG
 - TLA-2
 - TLB-2
 - TLA-1

- Link Clamp
 - LKA
 - LKC
 - LKW
 - LM/LJ
 - TMA-2
 - TMA-1

- Work Support
 - LD
 - LC
 - TNC
 - TC

- Air Sensing Lift Cylinder
 - LLW

- Compact Cylinder
 - LL
 - LLR
 - LLU
 - DP
 - DR
 - DS
 - DT

- Block Cylinder
 - DBA
 - DBC













- Control Valve
 - BZL
 - BZT
 - BZX/JZG

- Pallet Clamp
 - VS
 - VT









- Expansion Locating Pin
 - VL
 - VM
 - VJ
 - VK





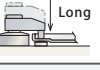
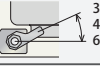







- Pull Stud Clamp
 - FP
 - FQ

- Customized Spring Cylinder
 - DWA/DWB

| Low Pressure Model MAX. 7MPa | |  Model LHA → P.289 |  Model LHC → P.319 |  Model LHS → P.331 |
|---------------------------------|---|---|--|---|
| Classification | | Double Action | Double Action Compact | Double Action Parallel Swing Action |
| Operating Pressure Range | | 1.5~7MPa | 1.5~7MPa | 1.5~7MPa |
| Standard Model | | External Dimensions → P.297 | External Dimensions → P.327 | External Dimensions → P.339 |
| Action Confirmation | Double End Rod Option for Dog  | External Dimensions → P.299 | — | ★ |
| | Air Sensing Manifold Option  | External Dimensions → P.301 | — | ★ |
| | Air Sensing Piping Option  | External Dimensions → P.303 | — | ★ |
| | Built-in Sensing Valve Model | — | — | — |
| Option | Quick Change Lever Option  | External Dimensions → P.305 | ★ | External Dimensions → P.341 |
| | Balance Lever Option  | External Dimensions → P.307 | ★ | External Dimensions → P.343 |
| | Long Stroke Option  | External Dimensions → P.309 | — | ★ |
| | Swing Angle Selectable Option  | External Dimensions → P.313 | ★ | External Dimensions → P.345 |
| Accessories | Lever  | LZH-T, LZH-F, LZH-B → P.318 | LZH-T → P.330 | LZH-T, LZH-F, LZH-B → P.348 |
| | Manifold Block  | LZY-MD | | → P.1025 |
| | Speed Control Valve Plug  | BZL, BZX, JZG | | → P.727 |

※ Please contact us for detail dimension at ★ part.

| High Pressure Model MAX. 35MPa | |  Model TLA-2 → P.387 |  Model TLB-2 → P.413 |  Model TLA-1 → P.431 |
|-----------------------------------|---|---|---|---|
| Classification | | Double Action Top Flange | Double Action Bottom Flange | Single Action (Spring Release) Top Flange |
| Operating Pressure Range | | 7~35MPa | 7~35MPa | 7~35MPa |
| Standard Model | | External Dimensions → P.395 | External Dimensions → P.421 | External Dimensions → P.439 |
| Option | Balance Lever Option  | External Dimensions → P.399 | External Dimensions → P.423 | — |
| | Long Stroke Option  | External Dimensions → P.403 | External Dimensions → P.425 | — |
| | Swing Angle Selectable Option  | External Dimensions → P.407 | External Dimensions → P.427 | — |
| Accessories | Lever  | TLZ-L2, TLZ-LB → P.412 | TLZ-L2, TLZ-LB → P.429 | TLZ-L2, TLZ-LB → P.443 |
| | Speed Control Valve Plug  | BZT, JZG | | → P.727 |
| | G-Thread Fitting  | G-Thread Fitting (Made by Ihara Science) | | → P.1039 |

| Low Pressure Model MAX. 7MPa | |  Model LHW → P.349 |  Model LT/LG → P.367 |
|---------------------------------|---|---|--|
| Classification | | Double Action Built-in Sensing Valve | Single Action (Spring Release) |
| Operating Pressure Range | | 1.5~7MPa | 2.5~7MPa |
| Standard Model | | — | External Dimensions → P.375 |
| Action Confirmation | Double End Rod Option for Dog  Able to Install Dog | — | — |
| | Air Sensing Manifold Option  | — | — |
| | Air Sensing Piping Option  Able to Install Air Sensor | — | — |
| | Built-in Sensing Valve Model | External Dimensions → P.359 | — |
| Option | Quick Change Lever Option  | ★ | External Dimensions → P.377 |
| | Balance Lever Option  | ★ | External Dimensions → P.379 |
| | Long Stroke Option  Long | — | — |
| | Swing Angle Selectable Option  30° 45° 60° | ★ | External Dimensions → P.381 |
| Accessories | Lever  | LZH-T → P.366 | LZ-LE1、LZ-LE2 LZH-F、LZH-B → P.384 |
| | Manifold Block  | — | LZ-MS → P.1026 |
| | Speed Control Valve Plug  | BZL、BZX、JZG | → P.727 |

High-Power Series

Pneumatic Series

Hydraulic Series

Valve / Coupler Hydraulic Unit

Manual Operation Accessories

Cautions / Others

Hole Clamp

SFA
SFC

Swing Clamp

LHA
LHC
LHS
LHW
LT/LG
TLA-2
TLB-2
TLA-1

Link Clamp

LKA
LKC
LKW
LM/LJ
TMA-2
TMA-1

Work Support

LD
LC
TNC
TC

Air Sensing Lift Cylinder

LLW

Compact Cylinder

LL
LLR
LLU
DP
DR
DS
DT

Block Cylinder

DBA
DBC

Control Valve

BZL
BZT
BZX/JZG

Pallet Clamp

VS
VT

Expansion Locating Pin

VL
VM
VJ
VK

Pull Stud Clamp

FP
FQ

Customized Spring Cylinder

DWA/DWB



High-Power Swing Clamp Hydraulic Double Action

Model **LHE**

2 sizes smaller with equivalent clamping force. Mechanical lock and hydraulic pressure allow for strong clamping and holding force. Refer to P. 13 for further information.

Hydraulic Double Action Compact Swing Clamp

PAT.

Model LHC

Low Pressure (1.5~7MPa)

High Speed • Compact



Index

| | |
|---|--------|
| Hydraulic Swing Clamp Digest | P.285 |
| Cross Section | P.320 |
| Action Description | P.320 |
| Model No. Indication | P.321 |
| Specifications | P.322 |
| Performance Curve | |
| Clamping Force Curve | P.323 |
| Allowable Swing Time Graph | P.325 |
| External Dimensions | |
| • Standard Model (LHC) | P.327 |
| Lever Design Dimensions | P.329 |
| Accessories | |
| • Material Swing Lever for LHC | P.330 |
| • Speed Control Valve • Plug (Common Items of Other Models) | P.727 |
| • Manifold Block (Common Items of Other Models) | P.1025 |
| Cautions | |
| • Notes for Hydraulic Swing Clamps | P.445 |
| • Cautions (Common) | P.1043 |
| • Installation Notes | |
| • Hydraulic Fluid List | |
| • Notes on Hydraulic Cylinder Speed Control Circuit | |
| • Notes on Handling | |
| • Maintenance/Inspection | |
| • Warranty | |

Cross Section

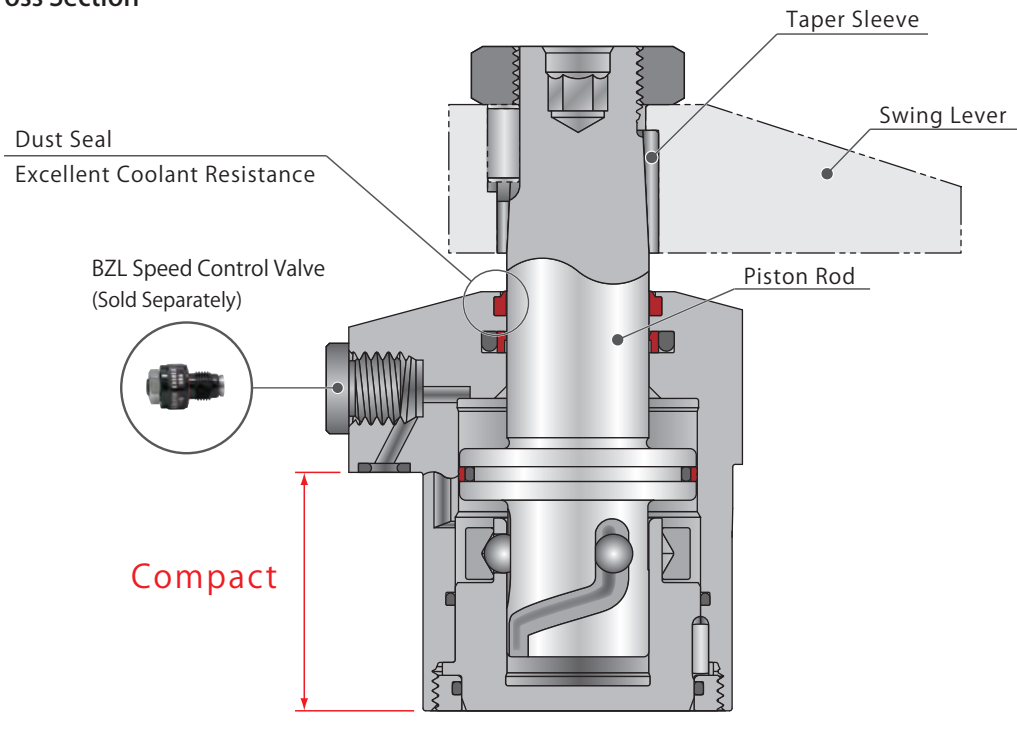

Compact

The dimension below the flange is shortened to enable smaller footprint fixtures. The compact body enables the internal fitting to limit interference and makes fixture designing more engineer friendly.

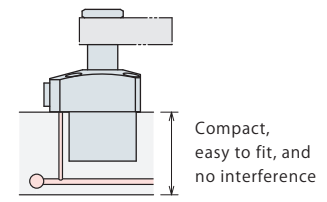

Able to Use Longer Levers

The long guide ratio allows for longer clamping levers by supporting the rod. The guide is located between the flange and at the edge of the rod.

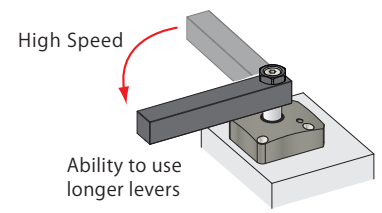

Excellent Coolant Resistance

Our exclusive dust seal is designed to protect against high pressure coolant. It also has high durability against chlorine-based coolant by using a sealing material with excellent chemical resistance.

High Speed and High Endurance with Rotation Mechanism

The resistance created by the swing action is minimized by having the outer race rotate in accordance with the steel ball movement. High endurance is achieved by enlarging rod diameter which decreases torque and by using bigger steel balls and making the lead groove. (Position repeatability for swing is within $\pm 0.5^\circ$.)

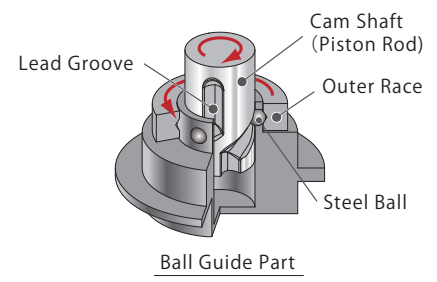

Able to Attach Speed Control Valve Directly

When fitting the gasket (-C option), it is able to attach the speed control valve with air venting function. (Speed control valve is sold separately.)

Action Description

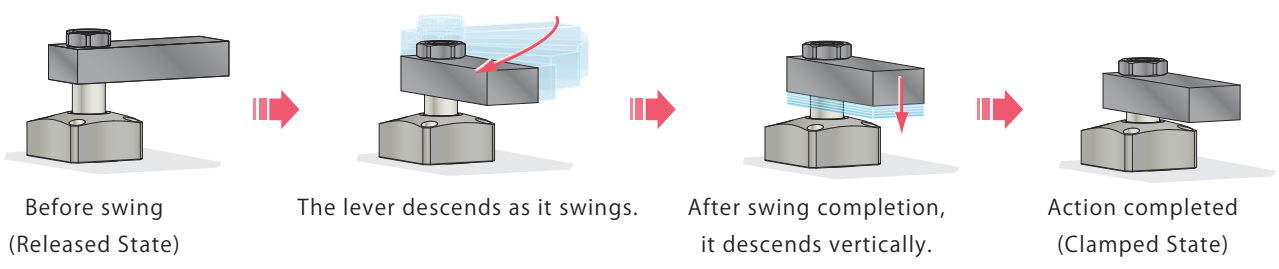

| |
|--------------------------------|
| High-Power Series |
| Pneumatic Series |
| Hydraulic Series |
| Valve / Coupler Hydraulic Unit |
| Manual Operation Accessories |
| Cautions / Others |

| |
|------------|
| Hole Clamp |
| SFA |
| SFC |

| |
|--------------------|
| Swing Clamp |
| LHA |
| LHC |
| LHS |
| LHW |
| LT/LG |
| TLA-2 |
| TLB-2 |
| TLA-1 |

| |
|------------|
| Link Clamp |
| LKA |
| LKC |
| LKW |
| LM/LJ |
| TMA-2 |
| TMA-1 |

| |
|--------------|
| Work Support |
| LD |
| LC |
| TNC |
| TC |

| |
|---------------------------|
| Air Sensing Lift Cylinder |
| LLW |

| |
|------------------|
| Compact Cylinder |
| LL |
| LLR |
| LLU |
| DP |
| DR |
| DS |
| DT |

| |
|----------------|
| Block Cylinder |
| DBA |
| DBC |

| |
|---------------|
| Control Valve |
| BZL |
| BZT |
| BZX/JZG |

| |
|--------------|
| Pallet Clamp |
| VS |
| VT |

| |
|------------------------|
| Expansion Locating Pin |
| VL |
| VM |
| VJ |
| VK |

| |
|-----------------|
| Pull Stud Clamp |
| FP |
| FQ |

| |
|----------------------------|
| Customized Spring Cylinder |
| DWA/DWB |

Model No. Indication

LHC **048** **0** - **C** **R**

1 2 3 4

1 Body Size

- 036** : $\phi D=36\text{mm}$
- 040** : $\phi D=40\text{mm}$
- 048** : $\phi D=48\text{mm}$
- 055** : $\phi D=55\text{mm}$
- 065** : $\phi D=65\text{mm}$

※ Outer diameter (ϕD) of the cylinder.

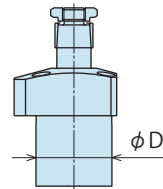

2 Design No.

0 : Revision Number

3 Piping Method

C : Gasket Option (With G Thread Plug)

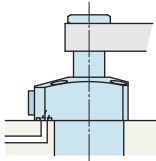

With G Thread Plug
 Able to attach the speed control valve

※ Speed control valve (BZL) is sold separately. Please refer to P.727.

4 Swing Direction when Clamping

R : Clockwise

L : Counter-Clockwise

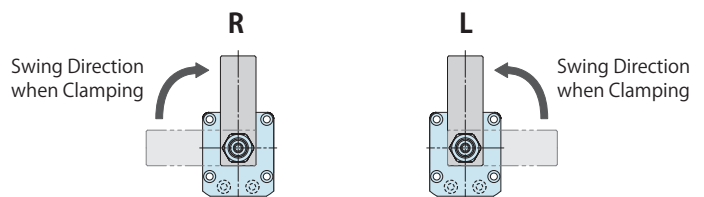

Specifications

| Model No. | LHC0360-C□ | LHC0400-C□ | LHC0480-C□ | LHC0550-C□ | LHC0650-C□ |
|---|---|--|--|--|--|
| Cylinder Area for Locking cm ² | 3.54 | 5.00 | 6.95 | 10.3 | 13.4 |
| Clamping Force ※ ¹ (Calculation Formula) kN | $F = \frac{P}{2.8233+0.0173 \times L}$ | $F = \frac{P}{1.9988+0.0103 \times L}$ | $F = \frac{P}{1.4386+0.0072 \times L}$ | $F = \frac{P}{0.9712+0.0039 \times L}$ | $F = \frac{P}{0.7485+0.0027 \times L}$ |
| Cylinder Inner Diameter mm | φ26 | φ31 | φ37 | φ44 | φ51 |
| Rod Diameter mm | φ15 | φ18 | φ22 | φ25 | φ30 |
| Cylinder Capacity cm ³ | Lock | 4.1 | 6.3 | 9.4 | 14.9 |
| | Release | 6.1 | 9.4 | 14.5 | 22.0 |
| Full Stroke mm | 11.5 | 12.5 | 13.5 | 14.5 | 16 |
| Swing Stroke (90°) mm | 5.5 | 6.5 | 7.5 | 8.5 | 10 |
| Vertical Stroke mm | 6 | 6 | 6 | 6 | 6 |
| Swing Angle Accuracy | 90° ±3° | | | | |
| Swing Completion Position Repeatability | ±0.5° | | | | |
| Max. Operating Pressure MPa | 7.0 | | | | |
| Min. Operating Pressure ※ ² MPa | 1.5 | | | | |
| Withstanding Pressure MPa | 10.5 | | | | |
| Operating Temperature °C | 0~70 | | | | |
| Usable Fluid | General Hydraulic Oil Equivalent to ISO-VG-32 | | | | |
| Mass ※ ³ kg | 0.6 | 0.8 | 1.2 | 1.8 | 2.4 |

Notes ※1. F : Clamping Force (kN), P : Supply Hydraulic Pressure (MPa),
L : Distance between the piston center and the clamping point (mm).

※2. Minimum pressure to operate the clamp without load.

※3. Mass of single swing clamp including taper sleeve and nut.

1. Please refer to P.445 and P.446 for cautions and tightening torque when mounting the cylinder body and swing lever.

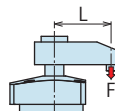

High-Power Series

Pneumatic Series

Hydraulic Series

Valve / Coupler Hydraulic Unit

Manual Operation Accessories

Cautions / Others

Hole Clamp

SFA
SFC

Swing Clamp

LHA
LHC
LHS
LHW
LT/LG
TLA-2
TLB-2
TLA-1

Link Clamp

LKA
LKC
LKW
LM/LJ
TMA-2
TMA-1

Work Support

LD
LC
TNC
TC

Air Sensing Lift Cylinder

LLW

Compact Cylinder

LL
LLR
LLU
DP
DR
DS
DT

Block Cylinder

DBA
DBC

Control Valve

BZL
BZT
BZX/JZG

Pallet Clamp

VS
VT

Expansion Locating Pin

VL
VM
VJ
VK

Pull Stud Clamp

FP
FQ

Customized Spring Cylinder

DWA/DWB

Clamping Force Curve

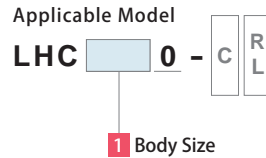
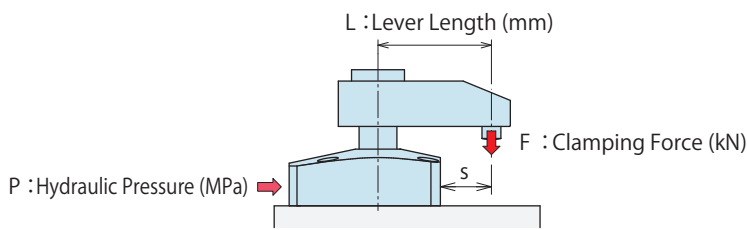

(Example) When using LHC0480,

Supply Hydraulic Pressure 5.0MPa, Lever Length L=50mm, the clamping force is about 2.8kN.

Notes

1. Tables and graphs shown are the relationships between the clamping force (kN) and supply hydraulic pressure (MPa).
 2. Cylinder output (when L=0) cannot be calculated from the calculation formula of clamping force.
 3. There may be no lever swing action with large inertia depending on supply hydraulic pressure or lever mounting position.
 4. The clamping force is shown with lever in the locked position.
 5. The clamping force varies depending on the lever length. Set the supply hydraulic pressure suitable to the lever length.
 6. Using in the non-usable range may damage the clamp and lead to fluid leakage.
 7. The tables and graphs are only for reference. The exact results should be calculated based on the clamping force calculation formula.
- ※1. F: Clamping Force (kN), P: Supply Hydraulic Pressure (MPa), L: Lever Length (mm)

| LHC0360 | | Clamping Force Calculation Formula ^{※1} (kN) $F = P / (2.8233 + 0.0173 \times L)$ | | | | | | | | | |
|-------------------------------|---------------------|--|------|------|------|------|-------|-------|-------|----------------------|----------------------------|
| Hydraulic Pressure (MPa) | Cylinder Force (kN) | Clamping Force (kN) | | | | | | | | Non-Usable Range (■) | Max. Lever Length (L) (mm) |
| | | Lever Length L(mm) | | | | | | | | | |
| | | L=30 | L=40 | L=50 | L=60 | L=80 | L=100 | L=120 | L=140 | | |
| 7 | 2.5 | 2.1 | 2.0 | 1.9 | 1.8 | 1.7 | | | | | 95 |
| 6.5 | 2.3 | 1.9 | 1.8 | 1.8 | 1.7 | 1.5 | 1.4 | | | | 107 |
| 6 | 2.1 | 1.8 | 1.7 | 1.6 | 1.6 | 1.4 | 1.3 | 1.2 | | | 122 |
| 5.5 | 2.0 | 1.6 | 1.6 | 1.5 | 1.4 | 1.3 | 1.2 | 1.1 | 1.0 | | 143 |
| 5 | 1.8 | 1.5 | 1.4 | 1.4 | 1.3 | 1.2 | 1.1 | 1.0 | 1.0 | | 150 |
| 4.5 | 1.6 | 1.3 | 1.3 | 1.2 | 1.2 | 1.1 | 1.0 | 0.9 | 0.9 | | 150 |
| 4 | 1.4 | 1.2 | 1.1 | 1.1 | 1.0 | 1.0 | 0.9 | 0.8 | 0.8 | | 150 |
| 3.5 | 1.2 | 1.0 | 1.0 | 0.9 | 0.9 | 0.8 | 0.8 | 0.7 | 0.7 | | 150 |
| 3 | 1.1 | 0.9 | 0.9 | 0.8 | 0.8 | 0.7 | 0.7 | 0.6 | 0.6 | | 150 |
| 2.5 | 0.9 | 0.7 | 0.7 | 0.7 | 0.6 | 0.6 | 0.5 | 0.5 | 0.5 | | 150 |
| 2 | 0.7 | 0.6 | 0.6 | 0.5 | 0.5 | 0.5 | 0.4 | 0.4 | 0.4 | | 150 |
| 1.5 | 0.5 | 0.4 | 0.4 | 0.4 | 0.4 | 0.4 | 0.3 | 0.3 | 0.3 | | 150 |
| Max. Operating Pressure (MPa) | | 7.0 | 7.0 | 7.0 | 7.0 | 7.0 | 6.7 | 6.0 | 5.5 | | |

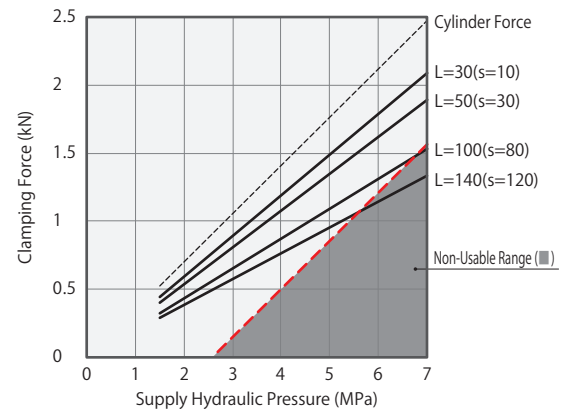

| LHC0400 | | Clamping Force Calculation Formula ^{※1} (kN) $F = P / (1.9988 + 0.0103 \times L)$ | | | | | | | | | |
|-------------------------------|---------------------|--|------|------|------|------|-------|-------|-------|----------------------|----------------------------|
| Hydraulic Pressure (MPa) | Cylinder Force (kN) | Clamping Force (kN) | | | | | | | | Non-Usable Range (■) | Max. Lever Length (L) (mm) |
| | | Lever Length L(mm) | | | | | | | | | |
| | | L=40 | L=50 | L=60 | L=70 | L=80 | L=100 | L=120 | L=150 | | |
| 7 | 3.5 | 2.9 | 2.8 | 2.7 | 2.6 | 2.5 | 2.3 | | | | 100 |
| 6.5 | 3.3 | 2.7 | 2.6 | 2.5 | 2.4 | 2.3 | 2.1 | | | | 112 |
| 6 | 3.0 | 2.5 | 2.4 | 2.3 | 2.2 | 2.1 | 2.0 | 1.9 | | | 128 |
| 5.5 | 2.8 | 2.3 | 2.2 | 2.1 | 2.0 | 1.9 | 1.8 | 1.7 | | | 148 |
| 5 | 2.5 | 2.1 | 2.0 | 1.9 | 1.8 | 1.8 | 1.7 | 1.5 | 1.4 | | 176 |
| 4.5 | 2.3 | 1.9 | 1.8 | 1.7 | 1.7 | 1.6 | 1.5 | 1.4 | 1.3 | | 210 |
| 4 | 2.0 | 1.7 | 1.6 | 1.5 | 1.5 | 1.4 | 1.3 | 1.2 | 1.1 | | 210 |
| 3.5 | 1.8 | 1.5 | 1.4 | 1.3 | 1.3 | 1.2 | 1.2 | 1.1 | 1.0 | | 210 |
| 3 | 1.5 | 1.2 | 1.2 | 1.1 | 1.1 | 1.1 | 1.0 | 0.9 | 0.8 | | 210 |
| 2.5 | 1.3 | 1.0 | 1.0 | 1.0 | 0.9 | 0.9 | 0.8 | 0.8 | 0.7 | | 210 |
| 2 | 1.0 | 0.8 | 0.8 | 0.8 | 0.7 | 0.7 | 0.7 | 0.6 | 0.6 | | 210 |
| 1.5 | 0.8 | 0.6 | 0.6 | 0.6 | 0.6 | 0.5 | 0.5 | 0.5 | 0.4 | | 210 |
| Max. Operating Pressure (MPa) | | 7.0 | 7.0 | 7.0 | 7.0 | 7.0 | 7.0 | 6.2 | 5.4 | | |

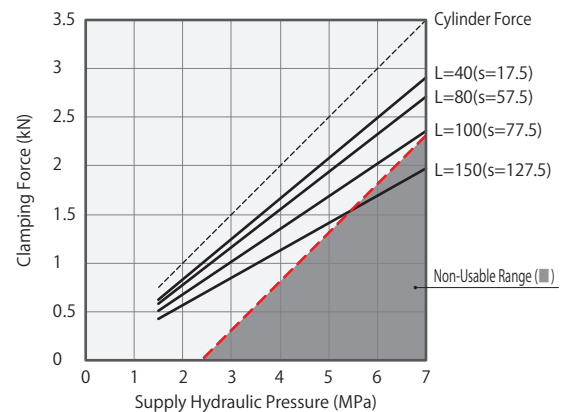

| LHC0480 | | Clamping Force Calculation Formula ^{※1} (kN) $F = P / (1.4386 + 0.0072 \times L)$ | | | | | | | | | |
|-------------------------------|---------------------|--|------|------|-------|-------|-------|-------|-------|----------------------|----------------------------|
| Hydraulic Pressure (MPa) | Cylinder Force (kN) | Clamping Force (kN) | | | | | | | | Non-Usable Range (■) | Max. Lever Length (L) (mm) |
| | | Lever Length L(mm) | | | | | | | | | |
| | | L=50 | L=60 | L=80 | L=100 | L=120 | L=140 | L=160 | L=200 | | |
| 7 | 4.9 | 3.9 | 3.7 | 3.5 | 3.2 | | | | | | 105 |
| 6.5 | 4.5 | 3.6 | 3.5 | 3.2 | 3.0 | | | | | | 118 |
| 6 | 4.2 | 3.3 | 3.2 | 3.0 | 2.8 | 2.6 | | | | | 134 |
| 5.5 | 3.8 | 3.1 | 2.9 | 2.7 | 2.5 | 2.4 | 2.2 | | | | 156 |
| 5 | 3.5 | 2.8 | 2.7 | 2.5 | 2.3 | 2.2 | 2.0 | 1.9 | | | 186 |
| 4.5 | 3.1 | 2.5 | 2.4 | 2.2 | 2.1 | 2.0 | 1.8 | 1.7 | 1.6 | | 230 |
| 4 | 2.8 | 2.2 | 2.1 | 2.0 | 1.9 | 1.7 | 1.6 | 1.5 | 1.4 | | 230 |
| 3.5 | 2.4 | 1.9 | 1.9 | 1.7 | 1.6 | 1.5 | 1.4 | 1.3 | 1.2 | | 230 |
| 3 | 2.1 | 1.7 | 1.6 | 1.5 | 1.4 | 1.3 | 1.2 | 1.2 | 1.0 | | 230 |
| 2.5 | 1.7 | 1.4 | 1.3 | 1.2 | 1.2 | 1.1 | 1.0 | 1.0 | 0.9 | | 230 |
| 2 | 1.4 | 1.1 | 1.1 | 1.0 | 0.9 | 0.9 | 0.8 | 0.8 | 0.7 | | 230 |
| 1.5 | 1.0 | 0.8 | 0.8 | 0.7 | 0.7 | 0.7 | 0.6 | 0.6 | 0.5 | | 230 |
| Max. Operating Pressure (MPa) | | 7.0 | 7.0 | 7.0 | 7.0 | 6.4 | 5.8 | 5.4 | 4.8 | | |

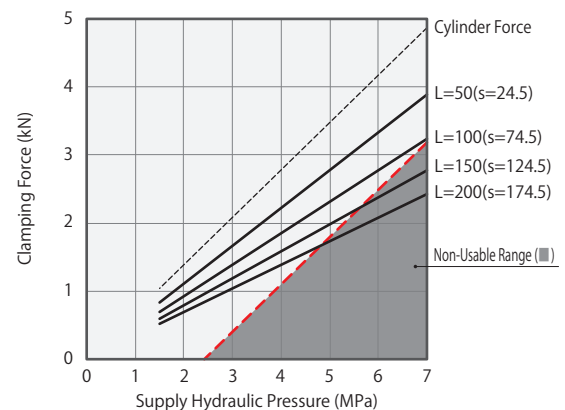

- High-Power Series
- Pneumatic Series
- Hydraulic Series**
- Valve / Coupler Hydraulic Unit
- Manual Operation Accessories
- Cautions / Others

Hole Clamp

- SFA
- SFC

Swing Clamp

- LHA
- LHC**
- LHS
- LHW
- LT/LG
- TLA-2
- TLB-2
- TLA-1

Link Clamp

- LKA
- LKC
- LKW
- LM/LJ
- TMA-2
- TMA-1

Work Support

- LD
- LC
- TNC
- TC

Air Sensing Lift Cylinder

- LLW

Compact Cylinder

- LL
- LLR
- LLU
- DP
- DR
- DS
- DT

Block Cylinder

- DBA
- DBC

Control Valve

- BZL
- BZT
- BZX/JZG

Pallet Clamp

- VS
- VT

Expansion Locating Pin

- VL
- VM
- VJ
- VK

Pull Stud Clamp

- FP
- FQ

Customized Spring Cylinder

- DWA/DWB

| LHC0550 | | Clamping Force Calculation Formula ^{**1} (kN) $F = P / (0.9712 + 0.0039 \times L)$ | | | | | | | | | |
|-------------------------------|---------------------|---|------|------|-------|-------|-------|-------|-------|-----------------------|----------------------------|
| Hydraulic Pressure (MPa) | Cylinder Force (kN) | Clamping Force (kN) | | | | | | | | Non-Usable Range (mm) | Max. Lever Length (L) (mm) |
| | | Lever Length L (mm) | | | | | | | | | |
| | | L=50 | L=60 | L=80 | L=100 | L=120 | L=140 | L=160 | L=200 | | |
| 7 | 7.2 | 6.0 | 5.8 | 5.4 | 5.1 | | | | | | 110 |
| 6.5 | 6.7 | 5.6 | 5.4 | 5.1 | 4.8 | 4.5 | | | | | 123 |
| 6 | 6.2 | 5.1 | 5.0 | 4.7 | 4.4 | 4.2 | | | | | 139 |
| 5.5 | 5.7 | 4.7 | 4.6 | 4.3 | 4.0 | 3.8 | 3.6 | | | | 159 |
| 5 | 5.2 | 4.3 | 4.1 | 3.9 | 3.7 | 3.5 | 3.3 | 3.1 | | | 187 |
| 4.5 | 4.6 | 3.9 | 3.7 | 3.5 | 3.3 | 3.1 | 3.0 | 2.8 | 2.6 | | 227 |
| 4 | 4.1 | 3.4 | 3.3 | 3.1 | 2.9 | 2.8 | 2.6 | 2.5 | 2.3 | | 245 |
| 3.5 | 3.6 | 3.0 | 2.9 | 2.7 | 2.6 | 2.4 | 2.3 | 2.2 | 2.0 | | 245 |
| 3 | 3.1 | 2.6 | 2.5 | 2.3 | 2.2 | 2.1 | 2.0 | 1.9 | 1.7 | | 245 |
| 2.5 | 2.6 | 2.1 | 2.1 | 1.9 | 1.8 | 1.7 | 1.6 | 1.6 | 1.4 | | 245 |
| 2 | 2.1 | 1.7 | 1.7 | 1.6 | 1.5 | 1.4 | 1.3 | 1.3 | 1.1 | | 245 |
| 1.5 | 1.6 | 1.3 | 1.2 | 1.2 | 1.1 | 1.0 | 1.0 | 0.9 | 0.9 | | 245 |
| Max. Operating Pressure (MPa) | | 7.0 | 7.0 | 7.0 | 7.0 | 6.6 | 5.9 | 5.4 | 4.8 | | |

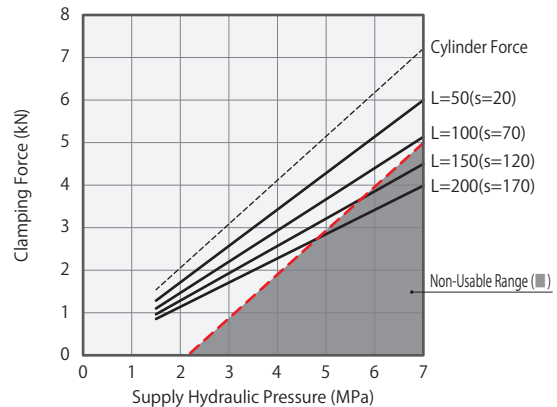

| LHC0650 | | Clamping Force Calculation Formula ^{**1} (kN) $F = P / (0.7485 + 0.0027 \times L)$ | | | | | | | | | |
|-------------------------------|---------------------|---|------|------|-------|-------|-------|-------|-------|-----------------------|----------------------------|
| Hydraulic Pressure (MPa) | Cylinder Force (kN) | Clamping Force (kN) | | | | | | | | Non-Usable Range (mm) | Max. Lever Length (L) (mm) |
| | | Lever Length L (mm) | | | | | | | | | |
| | | L=50 | L=60 | L=80 | L=100 | L=120 | L=140 | L=160 | L=200 | | |
| 7 | 9.4 | 7.9 | 7.7 | 7.2 | 6.9 | | | | | | 115 |
| 6.5 | 8.7 | 7.3 | 7.1 | 6.7 | 6.4 | 6.0 | | | | | 128 |
| 6 | 8.0 | 6.8 | 6.6 | 6.2 | 5.9 | 5.6 | 5.3 | | | | 144 |
| 5.5 | 7.4 | 6.2 | 6.0 | 5.7 | 5.4 | 5.1 | 4.9 | 4.6 | | | 166 |
| 5 | 6.7 | 5.7 | 5.5 | 5.2 | 4.9 | 4.7 | 4.4 | 4.2 | | | 194 |
| 4.5 | 6.0 | 5.1 | 4.9 | 4.7 | 4.4 | 4.2 | 4.0 | 3.8 | 3.5 | | 235 |
| 4 | 5.4 | 4.5 | 4.4 | 4.1 | 3.9 | 3.7 | 3.5 | 3.4 | 3.1 | | 260 |
| 3.5 | 4.7 | 4.0 | 3.8 | 3.6 | 3.4 | 3.3 | 3.1 | 3.0 | 2.7 | | 260 |
| 3 | 4.0 | 3.4 | 3.3 | 3.1 | 2.9 | 2.8 | 2.7 | 2.5 | 2.3 | | 260 |
| 2.5 | 3.4 | 2.8 | 2.7 | 2.6 | 2.4 | 2.3 | 2.2 | 2.1 | 1.9 | | 260 |
| 2 | 2.7 | 2.3 | 2.2 | 2.1 | 2.0 | 1.9 | 1.8 | 1.7 | 1.5 | | 260 |
| 1.5 | 2.0 | 1.7 | 1.6 | 1.6 | 1.5 | 1.4 | 1.3 | 1.3 | 1.2 | | 260 |
| Max. Operating Pressure (MPa) | | 7.0 | 7.0 | 7.0 | 7.0 | 6.7 | 6.1 | 5.6 | 4.9 | | |

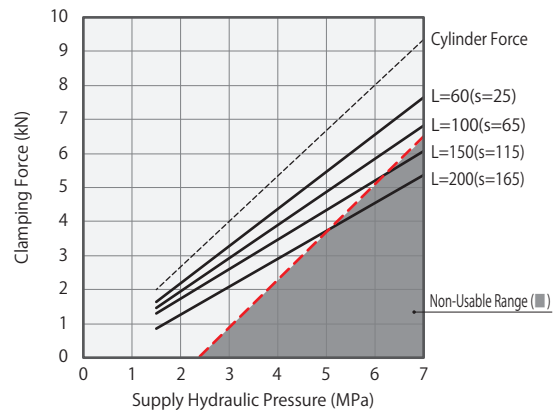

Allowable Swing Time Graph

Adjustment of Swing Time

The graph shows allowable swing time against lever inertia moment. Please make sure that the operating time is more than the operation time shown in the graph.

Excessive action speed can reduce stopping accuracy and damage internal parts.

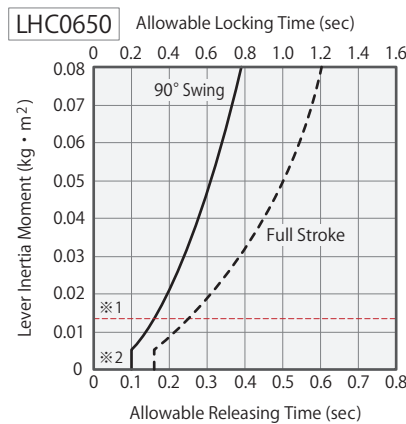
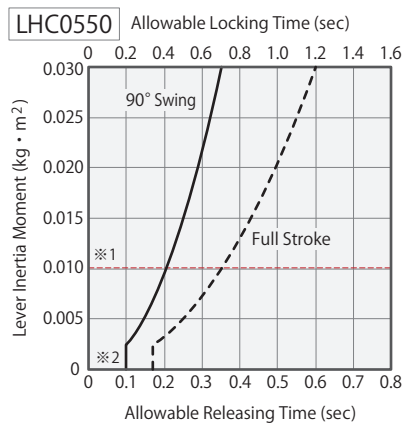
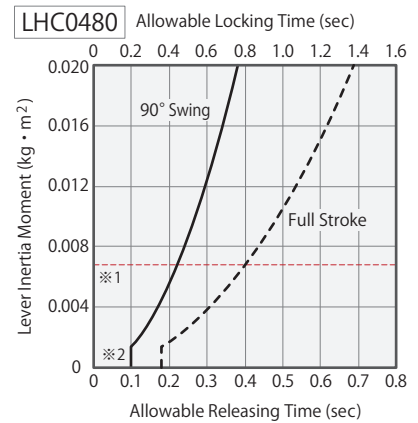
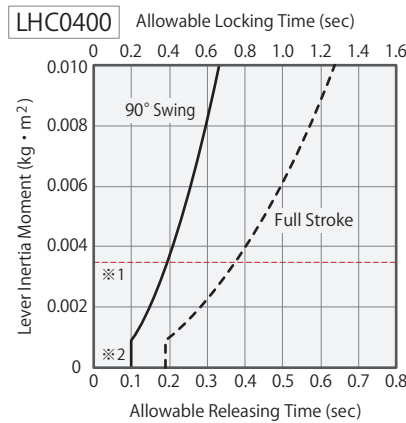
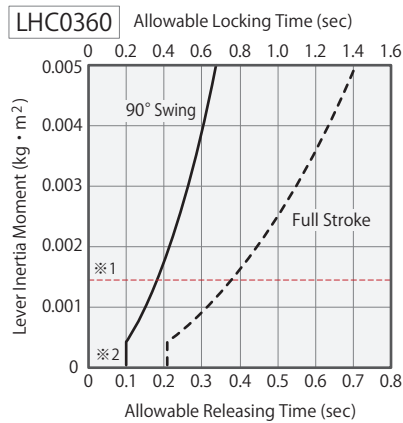
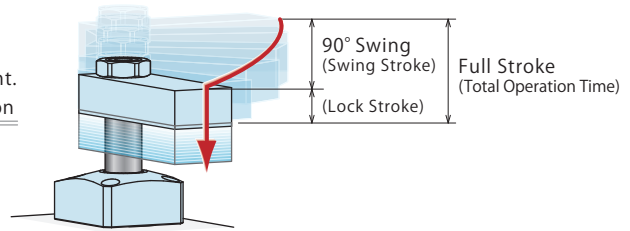

Notes

- ※1. It shows the inertia moment with material lever (LZH□-T).
- ※2. For any lever inertia moment, minimum 90° swing time should be 0.2 sec for locking and 0.1 sec for releasing or more.
 1. The graph shows the allowable action time in regard to the lever inertia moment when the piston rod operates at constant speed.
 2. There may be no lever swing action with large inertia depending on supply hydraulic pressure, oil flow and lever mounting position.
 3. For speed adjustment of clamp lever, please use meter-out flow control valve.
In case of meter-in control, the clamp lever may be accelerated by its own weight during swinging motion (clamp mounted horizontally) or the piston rod may be moving too fast. Please refer to P.1044 for speed control of the hydraulic cylinder.
 4. Excessive swing speed can reduce stopping accuracy and damage the internal parts.
 5. Please contact us if operational conditions differ from those shown on the graphs.

(How to read the allowable swing time graph)

When using LHC0480

Lever Inertia Moment : 0.0068kg·m²

① 90° Swing Time when Locking : About 0.44 sec or more

② 90° Swing Time when Releasing : About 0.22 sec or more

③ Total Lock Operation Time : About 0.8 sec or more

④ Total Release Operation Time : About 0.4 sec or more

1. The total operation time on the graph represents the allowable operation time when fully stroked.

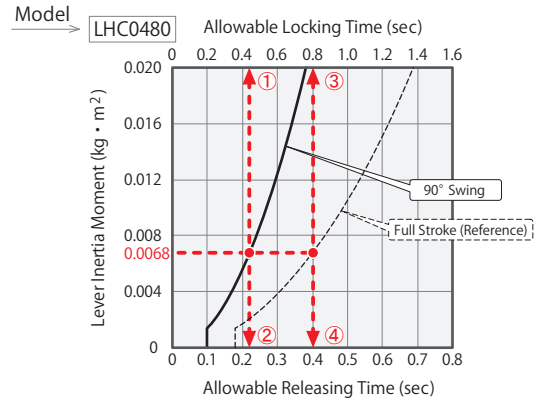

How to calculate inertia moment (Estimated)

I : Inertia Moment (kg·m²)

L,L₁,L₂,K,b : Length (m)

m,m₁,m₂,m₃ : Mass (kg)

① For a rectangular plate (cuboid), the rotating shaft is vertically on one side of the plate.

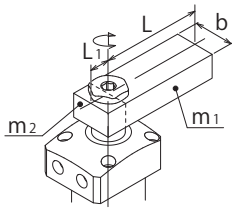

$$I = m_1 \frac{4L^2 + b^2}{12} + m_2 \frac{4L_1^2 + b^2}{12}$$

② For a rectangular plate (cuboid), the rotating shaft is vertically on the gravity center of the plate.

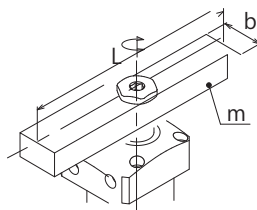

$$I = m \frac{L^2 + b^2}{12}$$

③ Load is applied on the lever front end.

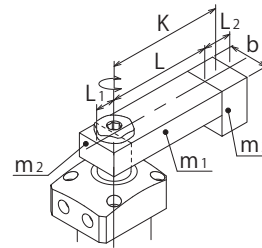

$$I = m_1 \frac{4L^2 + b^2}{12} + m_2 \frac{4L_1^2 + b^2}{12} + m_3 K^2 + m_3 \frac{L_2^2 + b^2}{12}$$

High-Power Series

Pneumatic Series

Hydraulic Series

Valve / Coupler Hydraulic Unit

Manual Operation Accessories

Cautions / Others

Hole Clamp

- SFA
- SFC

Swing Clamp

- LHA
- LHC**
- LHS
- LHW
- LT/LG
- TLA-2
- TLB-2
- TLA-1

Link Clamp

- LKA
- LKC
- LKW
- LM/LJ
- TMA-2
- TMA-1

Work Support

- LD
- LC
- TNC
- TC

Air Sensing Lift Cylinder

- LLW

Compact Cylinder

- LL
- LLR
- LLU
- DP
- DR
- DS
- DT

Block Cylinder

- DBA
- DBC

Control Valve

- BZL
- BZT
- BZX/JZG

Pallet Clamp

- VS
- VT

Expansion Locating Pin

- VL
- VM
- VJ
- VK

Pull Stud Clamp

- FP
- FQ

Customized Spring Cylinder

- DWA/DWB

External Dimensions

C : Gasket Option (With G Thread Plug)

※ The drawing shows the released state of LHC-CR.

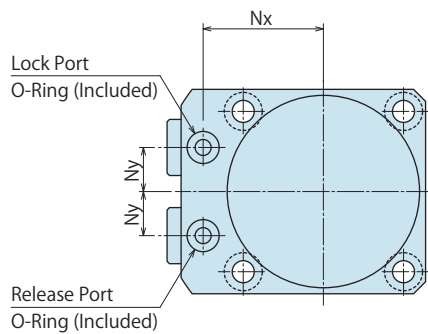
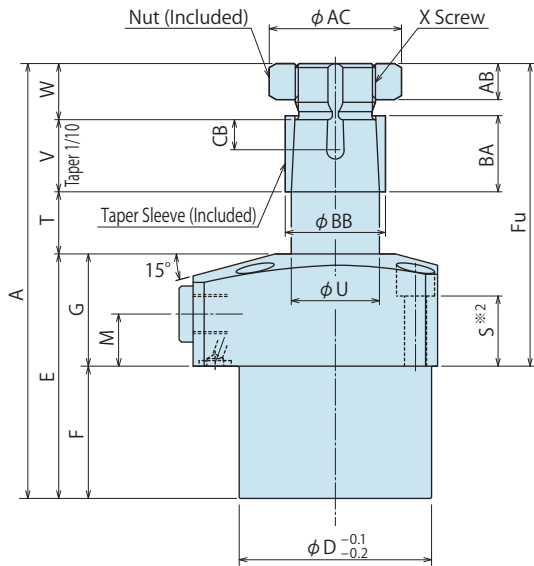
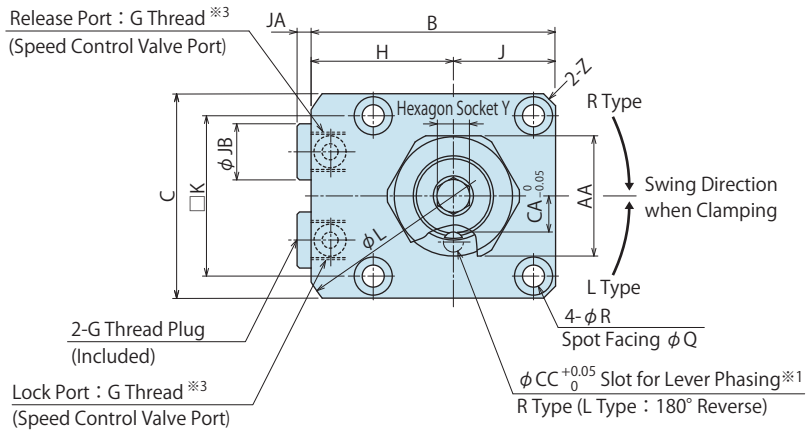

Machining Dimensions of Mounting Area

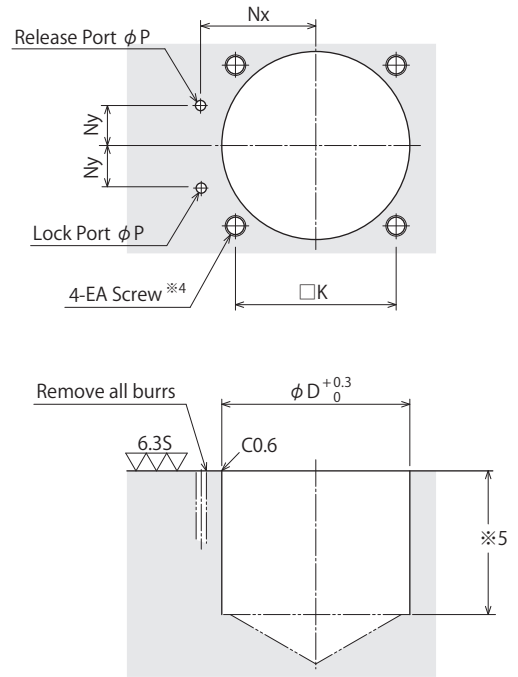

Notes

- ※4. EA tapping depth of the mounting bolt should be decided according to the mounting height referring to dimension 'S'.
- ※5. The depth of the body mounting hole φD should be decided according to the mounting height referring to dimension 'F'.

Notes

- ※1. The slot for lever phasing faces the oil port side when locked.
- ※2. Mounting bolts are not provided.
Please prepare them based on dimension 'S'.
- ※3. Speed control valve is sold separately.
Please refer to P.727 .

Model No. Indication

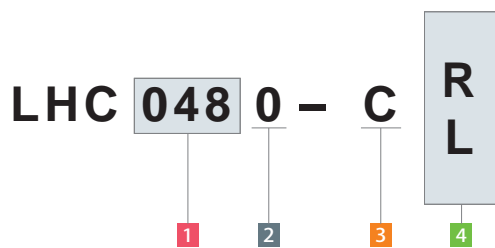

(Format Example : LHC0550-CR, LHC0750-CL)

- 1 Body Size
- 2 Design No.
- 3 Piping Method
- 4 Swing Direction when Clamping

External Dimensions and Machining Dimensions for Mounting

(mm)

| Model No. | LHC0360-C□ | LHC0400-C□ | LHC0480-C□ | LHC0550-C□ | LHC0650-C□ | |
|-------------------------|-------------------------|------------|------------|------------|------------|------|
| Full Stroke | 11.5 | 12.5 | 13.5 | 14.5 | 16 | |
| Swing Stroke (90°) | 5.5 | 6.5 | 7.5 | 8.5 | 10 | |
| Vertical Stroke | 6 | 6 | 6 | 6 | 6 | |
| A | 90.5 | 99.5 | 108.5 | 122 | 133.5 | |
| B | 49 | 54 | 61 | 69 | 81 | |
| C | 40 | 45 | 51 | 60 | 70 | |
| D | 36 | 40 | 48 | 55 | 65 | |
| E | 53 | 58 | 61 | 69.5 | 75.5 | |
| F | 28 | 33 | 33 | 39.5 | 44.5 | |
| Fu | 62.5 | 66.5 | 75.5 | 82.5 | 89 | |
| G | 25 | 25 | 28 | 30 | 31 | |
| H | 29 | 31.5 | 35.5 | 39 | 46 | |
| J | 20 | 22.5 | 25.5 | 30 | 35 | |
| K | 31.4 | 34 | 40 | 47 | 55 | |
| L | 66 | 73 | 83 | 88 | 106 | |
| M | 11 | 11 | 13 | 12 | 13 | |
| Nx | 23.5 | 26 | 30 | 33.5 | 39.5 | |
| Ny | 8 | 9 | 11 | 12 | 15 | |
| P | 3 | 3 | 3 | 3 | 5 | |
| Q | 7.5 | 9 | 9 | 11 | 11 | |
| R | 4.5 | 5.5 | 5.5 | 6.8 | 6.8 | |
| S | 16 | 15 | 17.5 | 17 | 17 | |
| T | 13.5 | 14.5 | 15.5 | 16.5 | 18 | |
| U | 15 | 18 | 22 | 25 | 30 | |
| V | 13 | 15 | 18 | 21 | 24 | |
| W | 11 | 12 | 14 | 15 | 16 | |
| X (Nominal×Pitch) | M14×1.5 | M16×1.5 | M20×1.5 | M22×1.5 | M27×1.5 | |
| Y | 5 | 6 | 8 | 8 | 10 | |
| Z (Chamfer) | C2 | C3 | C3 | C3 | C4 | |
| AA | 22 | 24 | 30 | 32 | 41 | |
| AB | 7 | 8 | 9 | 10 | 11 | |
| AC | 24.5 | 26.5 | 33 | 35.5 | 45 | |
| BA | 14 | 16 | 19 | 22 | 25 | |
| BB | 17 | 20 | 25 | 28 | 34 | |
| CA | 6 | 7 | 9 | 10 | 12.5 | |
| CB | 6.5 | 6.5 | 7.5 | 9.5 | 11.5 | |
| CC | 4 | 4 | 5 | 6 | 6 | |
| EA (Nominal×Pitch) | M4×0.7 | M5×0.8 | M5×0.8 | M6×1 | M6×1 | |
| JA | 3.5 | 3.5 | 3.5 | 3.5 | 4.5 | |
| JB | 14 | 14 | 14 | 14 | 19 | |
| Lock Port : G Thread | G1/8 | G1/8 | G1/8 | G1/8 | G1/4 | |
| Release Port : G Thread | G1/8 | G1/8 | G1/8 | G1/8 | G1/4 | |
| O-Ring | 1BP5 | 1BP5 | 1BP5 | 1BP5 | 1BP7 | |
| Cylinder | Lock | 4.1 | 6.3 | 9.4 | 14.9 | 21.4 |
| Capacity | cm ³ Release | 6.1 | 9.4 | 14.5 | 22.0 | 32.7 |
| Mass ^{※6} | kg | 0.6 | 0.8 | 1.2 | 1.8 | 2.4 |

Note ※6. Mass of single swing clamp including taper sleeve and nut.

- High-Power Series
- Pneumatic Series
- Hydraulic Series
- Valve / Coupler Hydraulic Unit
- Manual Operation Accessories
- Cautions / Others

Hole Clamp

- SFA
- SFC

Swing Clamp

- LHA
- LHC
- LHS
- LHW
- LT/LG
- TLA-2
- TLB-2
- TLA-1

Link Clamp

- LKA
- LKC
- LKW
- LM/LJ
- TMA-2
- TMA-1

Work Support

- LD
- LC
- TNC
- TC

Air Sensing Lift Cylinder

- LLW

Compact Cylinder

- LL
- LLR
- LLU
- DP
- DR
- DS
- DT

Block Cylinder

- DBA
- DBC

Control Valve

- BZL
- BZT
- BZX/JZG

Pallet Clamp

- VS
- VT

Expansion Locating Pin

- VL
- VM
- VJ
- VK

Pull Stud Clamp

- FP
- FQ

Customized Spring Cylinder

- DWA/DWB

Taper Lock Lever Design Dimension

※ Reference for designing taper lock swing lever.

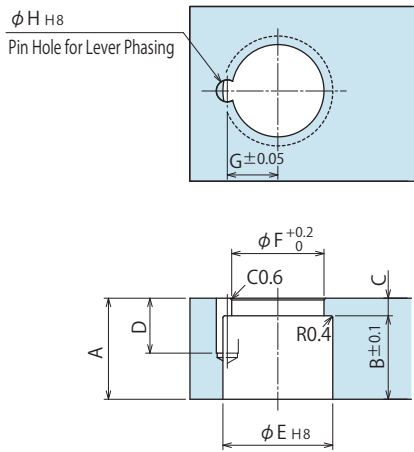
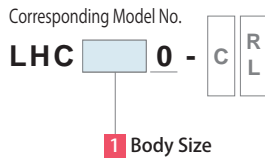

| Corresponding Model No. ※1 | LHC0360 | LHC0400 | LHC0480 | LHC0550 | LHC0650 |
|----------------------------|-----------------------------------|-----------------------------------|-----------------------------------|-----------------------------------|-----------------------------------|
| A | 17 | 19 | 23 | 26 | 29 |
| B | 14 | 16 | 19 | 22 | 25 |
| C | 3 | 3 | 4 | 4 | 4 |
| D | 10.5 | 10.5 | 12.5 | 14.5 | 16.5 |
| E | 17 ^{+0.027} ₀ | 20 ^{+0.033} ₀ | 25 ^{+0.033} ₀ | 28 ^{+0.033} ₀ | 34 ^{+0.039} ₀ |
| F | 15 | 17 | 21 | 23.5 | 29 |
| G | 8 | 9 | 11.5 | 13 | 15.5 |
| H | 4 ^{+0.018} ₀ | 4 ^{+0.018} ₀ | 5 ^{+0.018} ₀ | 6 ^{+0.018} ₀ | 6 ^{+0.018} ₀ |
| Phasing Pin (Reference) | $\phi 4(h8) \times 10$ | $\phi 4(h8) \times 10$ | $\phi 5(h8) \times 12$ | $\phi 6(h8) \times 14$ | $\phi 6(h8) \times 16$ |

Notes

- Swing lever should be designed with its length according to performance graph shown on P.323 and P.324 .
- If the swing lever is not in accordance with the dimensions shown above, performance may be degraded and damage can occur.
- The pin hole for lever phasing (ϕH) should be added if necessary.

Accessories : Material Swing Lever for Taper Lock Option

Model No. Indication

LZH 048 0 - T

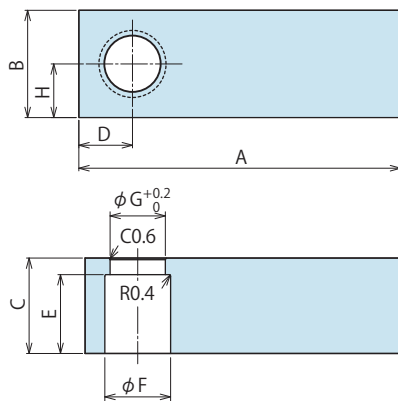
Size
(Refer to the table)Design No.
(Revision Number)

(mm)

| Model No. | LZH0360 -T | LZH0400 -T | LZH0480 -T | LZH0550 -T | LZH0650 -T |
|-------------------------|---------------|---------------|---------------|---------------|---------------|
| Corresponding Model No. | LHC0360 | LHC0400 | LHC0480 | LHC0550 | LHC0650 |
| A | 120 | 145 | 160 | 170 | 175 |
| B | 26 | 32 | 40 | 45 | 50 |
| C | 17 | 19 | 23 | 26 | 29 |
| D | 13 | 16 | 20 | 23 | 25 |
| E | 14 | 16 | 19 | 22 | 25 |
| F | 17 | 20 | 25 | 28 | 34 |
| G | 15 | 17 | 21 | 23.5 | 29 |
| H | 13 | 16 | 20 | 22.5 | 25 |

Notes

1. Material : S50CH
2. If necessary, the front end should be additionally machined.
3. When determining the phase, refer to the taper lock lever design dimensions for each model to do the additional machining.

High-Power
Series

Pneumatic Series

Hydraulic Series

Valve / Coupler
Hydraulic UnitManual Operation
Accessories

Cautions / Others

Hole Clamp

SFA
SFC

Swing Clamp

LHA
LHC
LHS
LHW
LT/LG
TLA-2
TLB-2
TLA-1

Link Clamp

LKA
LKC
LKW
LM/LJ
TMA-2
TMA-1

Work Support

LD
LC
TNC
TCAir Sensing
Lift Cylinder

LLW

Compact Cylinder

LL
LLR
LLU
DP
DR
DS
DT

Block Cylinder

DBA
DBC

Control Valve

BZL
BZT
BZX/JZG

Pallet Clamp

VS
VTExpansion
Locating PinVL
VM
VJ
VK

Pull Stud Clamp

FP
FQCustomized
Spring Cylinder

DWA/DWB

Cautions

● Notes for Design

- 1) Check Specifications
 - Please use each product according to the specifications.
- 2) Notes for Circuit Design
 - Please read "Notes on Hydraulic Cylinder Speed Control Circuit" on P. 1044 to assist with proper hydraulic circuit designing.
 - Ensure there is no possibility of supplying hydraulic pressure to the lock and release ports simultaneously.
- 3) Swing lever should be designed so that the inertia moment is small.
 - Large moment of inertia will degrade the lever's stopping accuracy and cause undue wear to the clamp. Additionally, the clamp may not function, depending on supplied hydraulic pressure and lever mounting position.
 - Please set the allowable operating time after the inertia moment is calculated. Please make sure that let the clamps work within allowable operating time referring to the allowable operating time graph.
- 4) When using on a welding fixture, the exposed area of piston rod should be protected.
 - If spatter gets onto the sliding surface it could lead to malfunction and fluid leakage.
- 5) When clamping on a sloped surface of the workpiece
 - Make sure the clamp surface and mounting surface of the clamp are parallel.

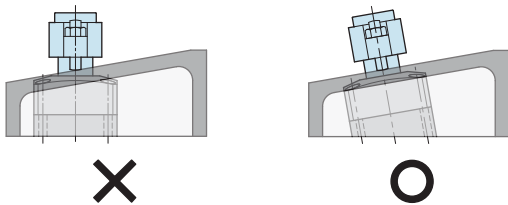

6) Notes for LHA-M/N, LHW

- When using air sensing swing clamp (LHA-M/N, LHW), make sure to check the Notes for Design • Installation • Use (Pages shown below).
 - Swing clamp with air sensing option LHA-M/N: Refer to P.315.
 - Swing clamp with air sensing valve LHW: Refer to P.353.

● Installation Notes

- 1) Check the Usable Fluid
 - Please use the appropriate fluid by referring to the Hydraulic Fluid List (P.1043).
- 2) Mounting the clamp
 - When mounting the clamp, use hexagon socket bolts as multiple bolt holes for mounting (with tensile strength of 12.9) and tighten them with the torque shown in the chart below. Tightening with greater torque than recommended can depress the seating surface or break the bolt.

| | Model No. | Thread Size | Tightening Torque (N·m) | |
|--------------------------|--|-----------------|-------------------------|-----|
| LHA LHC LHS LHW | LHA0360 / LHS0360 | M4×0.7 | 4.0 | |
| | LHA0400 / LHC0400 LHS0400 / LHW040□ | M5×0.8 | 8.0 | |
| | LHA0480 / LHC0480 LHS0480 / LHW048□ | M5×0.8 | 8.0 | |
| | LHA0550 / LHC0550 LHS0550 / LHW055□ | M6×1 | 14 | |
| | LHA0650 / LHC0650 LHS0650 / LHW065□ | M6×1 | 14 | |
| | LHA0750 / LHS0750 LHW0751 | M8×1.25 | 33 | |
| | LHA0900 / LHS0900 | M10×1.5 | 65 | |
| | LHA1050 / LHS1050 | M12×1.75 | 114 | |
| | LT/LG | LT0301 / LG0301 | M4×0.7 | 3.2 |
| | | LT036□ / LG036□ | M4×0.7 | 3.2 |
| LT040□ / LG040□ | | M5×0.8 | 6.3 | |
| LT048□ / LG048□ | | M5×0.8 | 6.3 | |
| LT055□ / LG055□ | | M6×1 | 10 | |
| LT065□ / LG065□ | | M6×1 | 10 | |
| LT075□ / LG075□ | | M8×1.25 | 25 | |
| LG090□ | | M10×1.5 | 58.8 | |
| LG105□ | | M12×1.75 | 98 | |
| TLA-2 TLB-2 TLA-1 | | TL□040□-□ | M5×0.8 | 6.9 |
| | TL□060□-□ | M6×1 | 11.8 | |
| | TL□080□-□ | M6×1 | 11.8 | |
| | TL□100□-□ | M8×1.25 | 25 | |
| | TL□160□-□ | M8×1.25 | 25 | |
| | TL□200□-□ | M10×1.5 | 58.8 | |
| | TL□250□-□ | M10×1.5 | 58.8 | |
| | TL□400□-□ | M12×1.75 | 98 | |

3) Mounting and removing the swing lever.

- Oil or debris on the mating surfaces of the lever, taper sleeve or piston rod can cause the rod to loosen. Clean carefully before assembly.
- Lever arm mounting bolt torques are shown below.

LHA/LHC/LHS/LHW/LT/LG Standard : Taper Lock Lever

| | 形式 | Thread Size | Tightening Torque (N·m) |
|--------------------------|--|-----------------|-------------------------|
| LHA LHC LHS LHW | LHA0360 / LHS0360 | M14×1.5 | 21 ~ 25 |
| | LHA0400 / LHC0400 LHS0400 / LHW040□ | M16×1.5 | 33 ~ 40 |
| | LHA0480 / LHC0480 LHS0480 / LHW048□ | M20×1.5 | 54 ~ 65 |
| | LHA0550 / LHC0550 LHS0550 / LHW055□ | M22×1.5 | 84 ~ 100 |
| | LHA0650 / LHC0650 LHS0650 / LHW065□ | M27×1.5 | 120 ~ 145 |
| | LHA0750 / LHS0750 LHW0751 | M30×1.5 | 175 ~ 210 |
| | LHA0900 / LHS0900 | M39×1.5 | 280 ~ 335 |
| | LHA1050 / LHS1050 | M48×1.5 | 333 ~ 400 |
| | LT/LG | LT0301 / LG0301 | M8×1 |
| LT036□ / LG036□ | | M10×1 | 15 ~ 18 |
| LT040□ / LG040□ | | M12×1.5 | 24 ~ 29 |
| LT048□ / LG048□ | | M16×1.5 | 37 ~ 45 |
| LT055□ / LG055□ | | M18×1.5 | 59 ~ 71 |
| LT065□ / LG065□ | | M22×1.5 | 93 ~ 112 |
| LT075□ / LG075□ | | M28×1.5 | 147 ~ 177 |
| LG090□ | | M36×1.5 | 235 ~ 282 |
| LG105□ | | M45×1.5 | 300 ~ 360 |

LHA/LHS-F Quick Change Lever, TLA-2/TLB-2/TLA-1 Standard

| | Model No. | Thread Size | Tightening Torque (N·m) | |
|--------------------------------|--|-------------|-------------------------|-----|
| LHA-F LHS-F LT-F LG-F | LT0301-F / LG0301-F | M5×0.8 | 7.5 | |
| | LHA0360-F / LHS0360-F LT036□-F / LG036□-F | M6 | 14 | |
| | LHA0400-F / LHS0400-F LT040□-F / LG040□-F | M8×1 | 33 | |
| | LHA0480-F / LHS0480-F LT048□-F / LG048□-F | M10×1.25 | 65 | |
| | LHA0550-F / LHS0550-F LT055□-F / LG055□-F | M12×1.5 | 100 ~ 114 | |
| | LHA0650-F / LHS0650-F LT065□-F / LG065□-F | M14×1.5 | 160 ~ 180 | |
| | LHA0750-F / LHS0750-F LT075□-F / LG075□-F | M16×1.5 | 250 ~ 280 | |
| | LHA0900-F / LHS0900-F LG090□-F | M20×2 | 500 ~ 540 | |
| | LHA1050-F / LHS1050-F LG105□-F | M24×2 | 760 ~ 810 | |
| | TLA-2 TLB-2 TLA-1 | TL□040□-□ | M6 | 13 |
| | | TL□060□-□ | M8×1 | 32 |
| | | TL□080□-□ | M8×1 | 32 |
| | | TL□100□-□ | M10×1.25 | 63 |
| | | TL□160□-□ | M12×1.5 | 100 |
| TL□200□-□ | | M14×1.5 | 160 | |
| | TL□250□-□ | M16×1.5 | 250 | |
| | TL□400□-□ | M20×2 | 500 | |

- If the piston rod is subjected to excessive torque or shock, the rod or the internal mechanism may be damaged. Observe the following points to prevent such shock.

During mounting

- ① When the clamp is positioned with fixture, determine the lever position, and temporarily tighten the nut for fixing the lever.
- ② Remove the clamp from a fixture, fix the lever by machine vise etc., and tighten the nut.

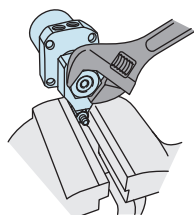

- ③ If clamp can't be removed from fixture for final tightening, secure the lever while tightening the nut. It is best to bring the lever to the middle of the swing stroke before tightening the nut.

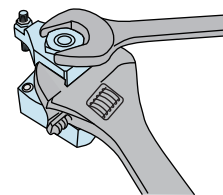

During removal

- ① While the clamp is in the fixture or vise, use a hex wrench to bring the arm to the middle of the swing stroke and then loosen the nut.
- ② Loosen the taper sleeve nut two or three turns then remove the lever with puller. Do not put any rotating torque on the piston rod.

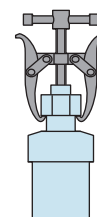

4) Swinging Speed Adjustment

- Adjust the speed following "Allowable Swing Time Graph". If the clamp operates too fast the parts will wear out leading to premature damage and ultimately complete equipment failure.
- Please make sure to release air from the circuit before adjusting speed. It will be difficult to adjust the speed accurately with air mixed in the circuit.
- Turn the speed control valve gradually from the low-speed side (small flow) to the high-speed side (large flow) to adjust the speed.

5) Checking looseness and retightening

- At the beginning of the machine installation, the bolt and nut may be tightened lightly. Check the looseness and re-tighten as required.

6) Notes on dual rod option (-D) for dog application.

- When attaching dog, set up the piston so that it will not turn around. Please secure the dog or cam and prevent any rotation or torque on the piston rod. Torque values for the mounting screw are shown in the table below.

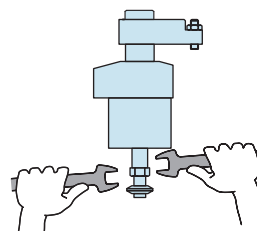

| Model No. | Thread Size | Tightening Torque (N·m) |
|-------------|-------------|-------------------------|
| LHA0360-□□D | M4×0.7 | 3.2 |
| LHA0400-□□D | M6×1 | 10 |
| LHA0480-□□D | M8×1.25 | 25 |
| LHA0550-□□D | M8×1.25 | 25 |
| LHA0650-□□D | M8×1.25 | 25 |
| LHA0750-□□D | M10×1.5 | 50 |
| LHA0900-□□D | M10×1.5 | 50 |
| LHA1050-□□D | M10×1.5 | 50 |

※ Please refer to P.1043 for common cautions.

• Installation Notes • Hydraulic Fluid List • Notes on Hydraulic Cylinder Speed Control Circuit
• Notes on Handling • Maintenance/Inspection • Warranty

High-Power Series

Pneumatic Series

Hydraulic Series

Valve / Coupler Hydraulic Unit

Manual Operation Accessories

Cautions / Others

Hole Clamp

SFA
SFC

Swing Clamp

LHA
LHC
LHS
LHW
LT/LG
TLA-2
TLB-2
TLA-1

Link Clamp

LKA
LKC
LKW
LM/LJ
TMA-2
TMA-1

Work Support

LD
LC
TNC
TC

Air Sensing Lift Cylinder

LLW

Compact Cylinder

LL
LLR
LLU
DP
DR
DS
DT

Block Cylinder

DBA
DBC

Control Valve

BZL
BZT
BZX/JZG

Pallet Clamp

VS
VT

Expansion Locating Pin

VL
VM
VJ
VK

Pull Stud Clamp

FP
FQ

Customized Spring Cylinder

DWA/DWB

● Cautions

● Installation Notes (For Hydraulic Series)

- 1) Check the Usable Fluid
 - Please use the appropriate fluid by referring to the Hydraulic Fluid List.
- 2) Procedure before Piping
 - The pipeline, piping connector and fixture circuits should be cleaned by thorough flushing.
 - The dust and cutting chips in the circuit may lead to fluid leakage and malfunction.
 - There is no filter provided with Kosmek' s product except for a part of valves which prevents foreign materials and contaminants from getting into the circuit.
- 3) Applying Sealing Tape
 - Wrap with tape 1 to 2 times following the screw direction.
 - Pieces of the sealing tape can lead to oil leakage and malfunction.
 - In order to prevent a foreign substance from going into the product during the piping work, it should be carefully cleaned before working.
- 4) Air Bleeding of the Hydraulic Circuit
 - If the hydraulic circuit has excessive air, the action time may become very long. If air enters the circuit after connecting the hydraulic port or under the condition of no air in the oil tank, please perform the following steps.
 - ① Reduce hydraulic pressure to less than 2MPa.
 - ② Loosen the cap nut of pipe fitting closest to the clamp by one full turn.
 - ③ Wiggle the pipeline to loosen the outlet of pipe fitting.
Hydraulic fluid mixed with air comes out.

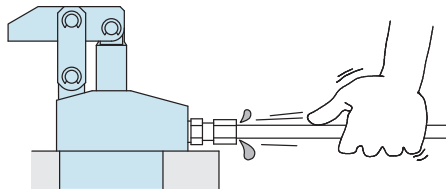

- ④ Tighten the cap nut after bleeding.
- ⑤ It is more effective to bleed air at the highest point inside the circuit or at the end of the circuit.
(Set an air bleeding valve at the highest point inside the circuit.)

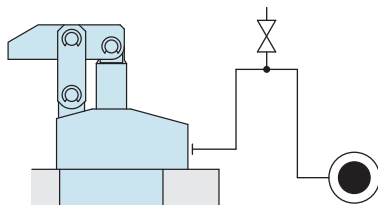

5) Checking Looseness and Retightening

- At the beginning of the machine installation, the bolt and nut may be tightened lightly. Check the looseness and re-tighten as required.

● Hydraulic Fluid List

| Maker | ISO Viscosity Grade ISO-VG-32 | |
|------------------------|-------------------------------|-----------------------------|
| | Anti-Wear Hydraulic Oil | Multi-Purpose Hydraulic Oil |
| Showa Shell Sekiyu | Tellus S2 M 32 | Morlina S2 B 32 |
| Idemitsu Kosan | Daphne Hydraulic Fluid 32 | Daphne Super Multi Oil 32 |
| JX Nippon Oil & Energy | Super Hyrando 32 | Super Mulpus DX 32 |
| Cosmo Oil | Cosmo Hydro AW32 | Cosmo New Mighty Super 32 |
| ExxonMobil | Mobil DTE 24 | Mobil DTE 24 Light |
| Matsumura Oil | Hydol AW-32 | |
| Castrol | Hyspin AWS 32 | |

Note As it may be difficult to purchase the products as shown in the table from overseas, please contact the respective manufacturer.

- High-Power Series
- Pneumatic Series
- Hydraulic Series
- Valve / Coupler Hydraulic Unit
- Manual Operation Accessories
- Cautions / Others

Cautions

- Installation Notes (For Hydraulic Series)
- Hydraulic Fluid List
- Notes on Hydraulic Cylinder Speed Control Circuit
- Notes on Handling
- Maintenance/Inspection
- Warranty

Company Profile

- Company Profile
- Our Products
- History

Index

- Search by Alphabetical Order

Sales Offices

● Notes on Hydraulic Cylinder Speed Control Unit



Please pay attention to the cautions below. Design the hydraulic circuit for controlling the action speed of hydraulic cylinder. Improper circuit design may lead to malfunctions and damages. Please review the circuit design in advance.

● Flow Control Circuit for Single Acting Cylinder

For spring return single acting cylinders, restricting flow during release can extremely slow down or disrupt release action. The preferred method is to control the flow during the lock action using a valve that has free-flow in the release direction. It is also preferred to provide a flow control valve at each actuator.

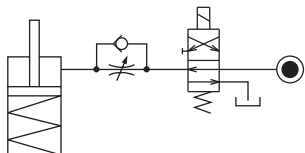

Accelerated clamping speed by excessive hydraulic flow to the cylinder may sustain damage. In this case add flow control to regulate flow. (Please add flow control to release flow if the lever weight is put on at the time of release action when using swing clamps.)

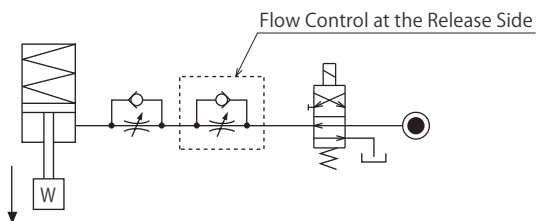

● Flow Control Circuit for Double Acting Cylinder

Flow control circuit for double acting cylinder should have meter-out circuits for both the lock and release sides. Meter-in control can have adverse effect by presence of air in the system.

However, in the case of controlling LKE, TMA, TLA, both lock side and release side should be meter-in circuit.

Refer to P.47 for speed adjustment of LKE.

For TMA and TLA, if meter-out circuit is used, abnormal high pressure is created, which causes oil leakage and damage.

【Meter-out Circuit】 (Except LKE/TMA/TLA)

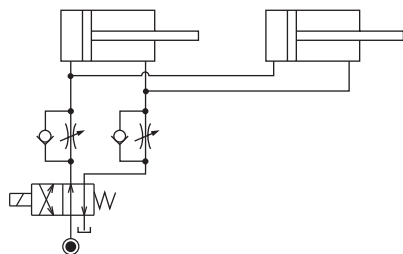

【Meter-in Circuit】 (LKE/TMA/TLA must be controlled with meter-in.)

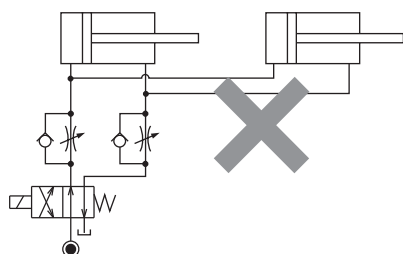

In the case of meter-out circuit, the hydraulic circuit should be designed with the following points.

- ① Single acting components should not be used in the same flow control circuit as the double acting components. The release action of the single acting cylinders may become erratic or very slow.

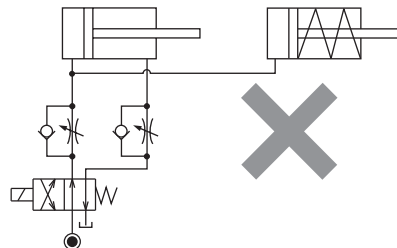

Refer to the following circuit when both the single acting cylinder and double acting cylinder are used together.

- Separate the control circuit.

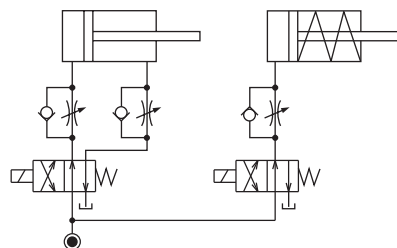

- Reduce the influence of double acting cylinder control unit. However, due to the back pressure in tank line, single action cylinder is activated after double action cylinder works.

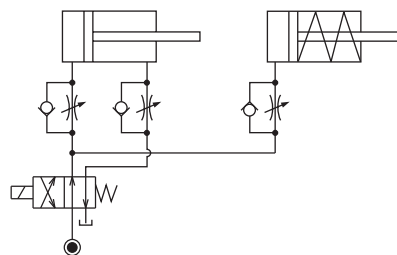

- ② In the case of meter-out circuit, the inner circuit pressure may increase during the cylinder action because of the fluid supply. The increase of the inner circuit pressure can be prevented by reducing the supplied fluid beforehand via the flow control valve. Especially when using sequence valve or pressure switches for clamping detection. If the back pressure is more than the set pressure then the system will not work as it is designed to.

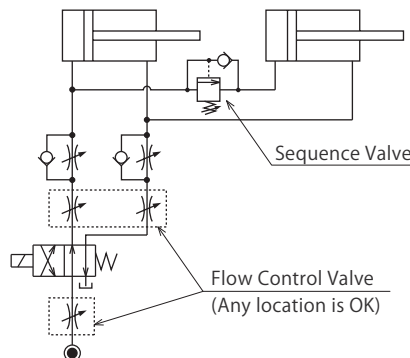

● Cautions

● Notes on Handling

- 1) It should be handled by qualified personnel.
 - The hydraulic machine and air compressor should be handled and maintained by qualified personnel.
- 2) Do not handle or remove the machine unless the safety protocols are ensured.
 - ① The machine and equipment can only be inspected or prepared when it is confirmed that the preventive devices are in place.
 - ② Before the machine is removed, make sure that the above-mentioned safety measures are in place. Shut off the air of hydraulic source and make sure no pressure exists in the hydraulic and air circuit.
 - ③ After stopping the machine, do not remove until the temperature cools down.
 - ④ Make sure there is no abnormality in the bolts and respective parts before restarting the machine or equipment.
- 3) Do not touch clamps (cylinder) while clamps (cylinder) is working. Otherwise, your hands may be injured due to clinching.

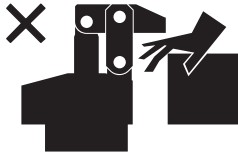

- 4) Do not disassemble or modify.
 - If the equipment is taken apart or modified, the warranty will be voided even within the warranty period.

● Maintenance and Inspection

- 1) Removal of the Machine and Shut-off of Pressure Source
 - Before the machine is removed, make sure that the above-mentioned safety measures are in place. Shut off the air of hydraulic source and make sure no pressure exists in the hydraulic and air circuit.
 - Make sure there is no abnormality in the bolts and respective parts before restarting.
- 2) Regularly clean the area around the piston rod and plunger.
 - If it is used when the surface is contaminated with dirt, it may lead to packing seal damage, malfunctioning, fluid leakage and air leaks.

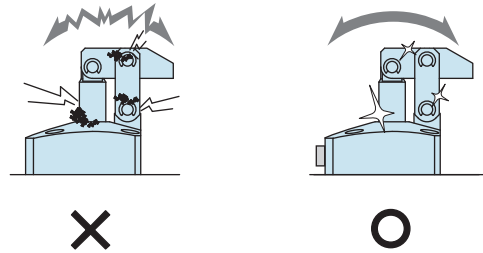

- 3) Please clean out the reference surface regularly (taper reference surface and seating surface) of locating machine. (VS/VT/VL/VM/VJ/VK/WVS/WM/WK/VX/VXF)
 - Location products, except VX/VXF model, can remove contaminants with cleaning functions. When installing pallets make sure there is no thick sludge like substances on pallets.
 - Continuous use with dirt on components will lead to locating functions not work properly, leaking and malfunction.

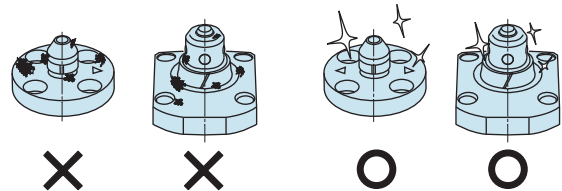

- 4) If disconnecting by couplers on a regular basis, air bleeding should be carried out daily to avoid air mixed in the circuit.
- 5) Regularly tighten nuts, bolts, pins, cylinders and pipe line to ensure proper use.
- 6) Make sure the hydraulic fluid has not deteriorated.
- 7) Make sure there is smooth action and no abnormal noise.
 - Especially when it is restarted after left unused for a long period, make sure it can be operated correctly.
- 8) The products should be stored in the cool and dark place without direct sunshine or moisture.
- 9) Please contact us for overhaul and repair.

Cautions

[Installation Notes
\(For Hydraulic Series\)](#)
[Hydraulic Fluid List](#)
[Notes on Hydraulic Cylinder
Speed Control Circuit](#)
[Notes on Handling](#)
[Maintenance/
Inspection](#)
[Warranty](#)

Company Profile

[Company Profile](#)
[Our Products](#)
[History](#)

Index

[Search by
Alphabetical Order](#)

Sales Offices

● Warranty

1) Warranty Period

- The product warranty period is 18 months from shipment from our factory or 12 months from initial use, whichever is earlier.

2) Warranty Scope

- If the product is damaged or malfunctions during the warranty period due to faulty design, materials or workmanship, we will replace or repair the defective part at our expense.

Defects or failures caused by the following are not covered.

- ① If the stipulated maintenance and inspection are not carried out.
- ② If the product is used while it is not suitable for use based on the operator's judgment, resulting in defect.
- ③ If it is used or handled in inappropriate way by the operator.
(Including damage caused by the misconduct of the third party.)
- ④ If the defect is caused by reasons other than our responsibility.
- ⑤ If repair or modifications are carried out by anyone other than Kosmek, or without our approval and confirmation, it will void warranty.
- ⑥ Other caused by natural disasters or calamities not attributable to our company.
- ⑦ Parts or replacement expenses due to parts consumption and deterioration.
(Such as rubber, plastic, seal material and some electric components.)

Damages excluding from direct result of a product defect shall be excluded from the warranty.

Control Valve

Model BZL

Model BZT

Model BZX

Model JZG



Directly mounted to clamps, flow control valve • Air bleeding • plug

- Directly mounted to clamps



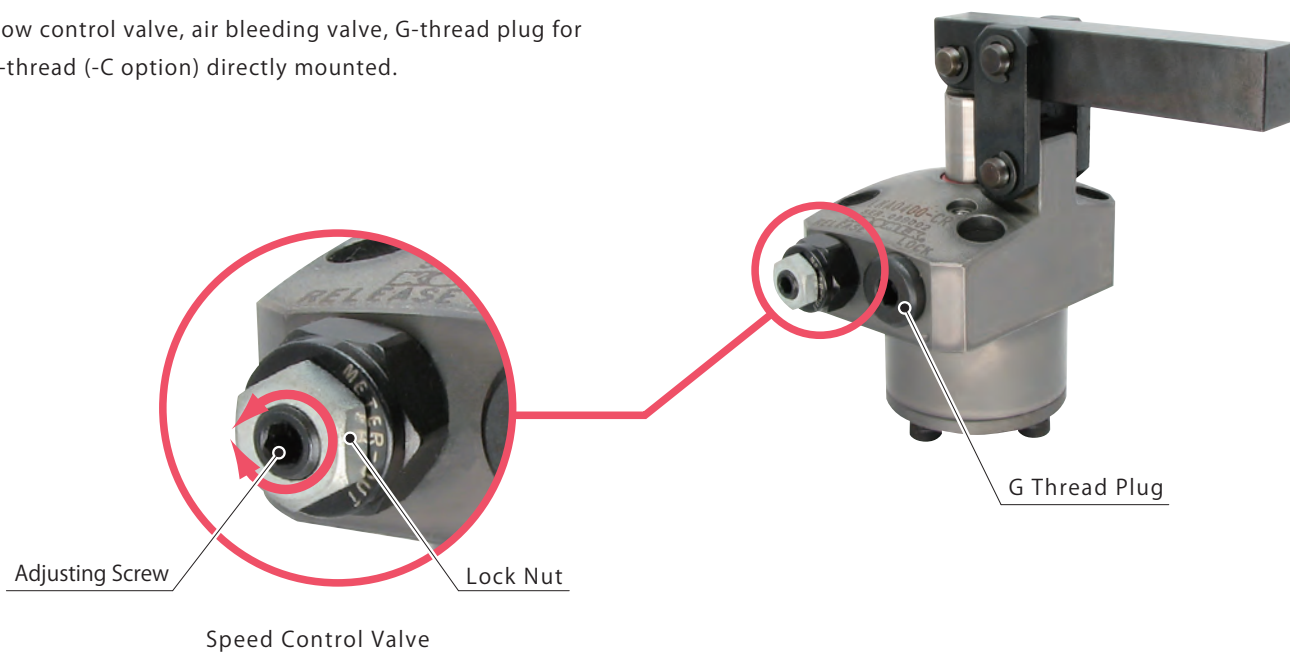

Flow control valve, air bleeding valve, G-thread plug for G-thread (-C option) directly mounted.

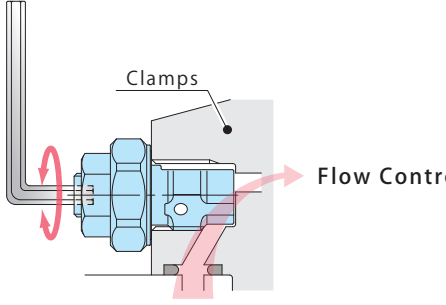
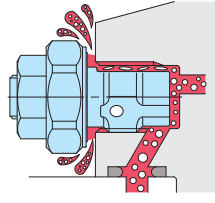

Speed Control Valve
Model BZL
Model BZT

Air Bleed Valve
Model BZX

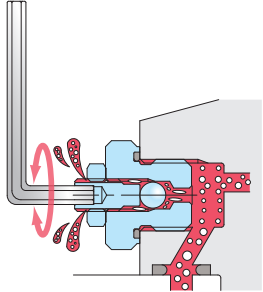
G Thread Plug
Model JZG

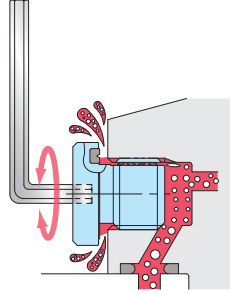
| | Operating Pressure Range | Action Description |
|---|--------------------------|--|
| <p>Speed Control Valve (For Low Pressure)</p> <p>Model BZL → P.729</p>  | 7MPa or less | <p>Adjust the flow by wrench. It can adjust the clamping action speed individually.</p>  |
| <p>Speed Control Valve (For High Pressure)</p> <p>Model BZT → P.733</p> | 35MPa or less | <p>Air bleeding in the circuit is possible by loosening flow control valve.</p>  |
| <p>Air Bleed Valve</p> <p>Model BZX → P.735</p>  | 25MPa or less | <p>Air bleeding in the circuit is possible by wrench.</p>  |
| <p>G Thread Plug</p> <p>Model JZG → P.737</p>  | 35MPa or less | <p>Air bleeding in the circuit is possible by loosening G thread plug.</p>  |

High-Power Series

Pneumatic Series

Hydraulic Series

Valve / Coupler Hydraulic Unit

Manual Operation Accessories

Cautions / Others

Hole Clamp

- SFA
- SFC

Swing Clamp

- LHA
- LHC
- LHS
- LHW
- LT/LG
- TLA-2
- TLB-2
- TLA-1

Link Clamp

- LKA
- LKC
- LKW
- LM/LJ
- TMA-2
- TMA-1

Work Support

- LD
- LC
- TNC
- TC

Air Sensing Lift Cylinder

- LLW

Compact Cylinder

- LL
- LLR
- LLU
- DP
- DR
- DS
- DT

Block Cylinder

- DBA
- DBC

Control Valve

- BZL**
- BZT**
- BZX/JZG**

Pallet Clamp

- VS
- VT

Expansion Locating Pin

- VL
- VM
- VJ
- VK

Pull Stud Clamp

- FP
- FQ

Customized Spring Cylinder

- DWA/DWB

Model No. Indication (Speed Control Valve for Low Pressure)

BZL 0 **10** **0** - **B**

1 2 3



1 G Thread Size

- 10 : Thread Part G1/8A Thread
- 20 : Thread Part G1/4A Thread
- 30 : Thread Part G3/8A Thread

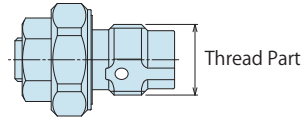

2 Design No.

- 0 : Revision Number

3 Control Method

- A : Meter-in
- B : Meter-out

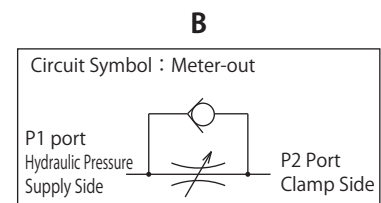
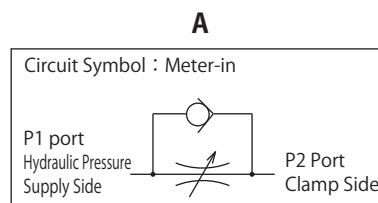

Specifications

| Model No. | BZL0100-A | BZL0200-A | BZL0300-A | BZL0100-B | BZL0200-B | BZL0300-B | |
|---------------------------------|---|-----------|-----------|-----------|-----------|-----------|--------|
| Max. Operating Pressure | MPa | | | 7 | | | |
| Withstanding Pressure | MPa | | | 10.5 | | | |
| Control Method | Meter-in | | | Meter-out | | | |
| G Thread Size | G1/8A | G1/4A | G3/8A | G1/8A | G1/4A | G3/8A | |
| Cracking Pressure | MPa | | | 0.12 | | | |
| Max. Passage Area | mm ² | 2.6 | 5.0 | 11.6 | 2.6 | 5.0 | 10.2 |
| Usable Fluid | General Hydraulic Oil Equivalent to ISO-VG-32 | | | | | | |
| Operating Temperature | °C | | | | | | 0 ~ 70 |
| Tightening Torque for Main Body | N·m | 10 | 25 | 35 | 10 | 25 | 35 |

- Notes
1. Minimum passage area when fully opened is the same as the maximum passage area in the table above.
 2. It must be mounted with recommended torque. Because of the structure of the metal seal, if mounting torque is insufficient, the flow control valve may not be able to adjust the flow rate.
 3. Don't use used BZL to other clamps.
Flow control will not be made because the bottom depth difference of G thread makes metal seal insufficient.

Applicable Products

| Model No. | DBA (Single Action) Block Cylinder | DBC (Single Action) Block Cylinder | LC (Single Action) Work Support | LHA (Double Action) Swing Clamp | LHC (Double Action) Swing Clamp | LHE (Double Action) High-Power Swing Clamp | LHS (Double Action) Swing Clamp | LHW (Double Action) Swing Clamp |
|-----------|------------------------------------|------------------------------------|--|--|--|--|--|--|
| BZL0100-A | (DBA0250-C□) (DBA0320-C□) | (DBC0250-C□) (DBC0320-C□) | LC0402-C□□□ LC0482-C□□□ LC0552-C□□□ LC0652-C□□□ | (LHA0360-C□□□) (LHA0400-C□□□) (LHA0480-C□□□) (LHA0550-C□□□) | (LHC0360-C□□□) (LHC0400-C□□□) (LHC0480-C□□□) (LHC0550-C□□□) | / | (LHS0360-C□□□) (LHS0400-C□□□) (LHS0480-C□□□) (LHS0550-C□□□) | (LHW0400-C□□□) (LHW0480-C□□□) (LHW0550-C□□□) |
| BZL0100-B | DBA0250-C□ DBA0320-C□ | DBC0250-C□ DBC0320-C□ | / | LHA0360-C□□□ LHA0400-C□□□ LHA0480-C□□□ LHA0550-C□□□ | LHC0360-C□□□ LHC0400-C□□□ LHC0480-C□□□ LHC0550-C□□□ | LHE0300-C□ LHE0360-C□ LHE0400-C□ LHE0480-C□ LHE0550-C□ | LHS0360-C□□□ LHS0400-C□□□ LHS0480-C□□□ LHS0550-C□□□ | LHW0400-C□□□ LHW0480-C□□□ LHW0550-C□□□ |
| BZL0200-A | (DBA0400-C□) (DBA0500-C□) | (DBC0400-C□) (DBC0500-C□) | LC0752-C□□□ LC0902-C□□□ | (LHA0650-C□□□) (LHA0750-C□□□) | (LHC0650-C□□□) | / | (LHS0650-C□□□) (LHS0750-C□□□) | (LHW0650-C□□□) |
| BZL0200-B | DBA0400-C□ DBA0500-C□ | DBC0400-C□ DBC0500-C□ | / | LHA0650-C□□□ LHA0750-C□□□ | LHC0650-C□□□ | / | LHS0650-C□□□ LHS0750-C□□□ | LHW0650-C□□□ |
| BZL0300-A | / | / | / | (LHA0900-C□□□) (LHA1050-C□□□) | / | / | (LHS0900-C□□□) (LHS1050-C□□□) | / |
| BZL0300-B | / | / | / | LHA0900-C□□□ LHA1050-C□□□ | / | / | LHS0900-C□□□ LHS1050-C□□□ | / |

| Model No. | LT/LG (Single Action) Swing Clamp | LKA (Double Action) Link Clamp | LKC (Double Action) Link Clamp | LKE (Double Action) High-Power Link Clamp | LKW (Double Action) Link Clamp | LM/LJ (Single Action) Link Clamp | LL (Double Action) Linear Cylinder | LLR (Double Action) Linear Cylinder |
|-----------|--|--|--|--|--|--|--|--|
| BZL0100-A | LT0360-C□ LT0400-C□ LT0480-C□ LT0550-C□ | (LKA0360-C□□□) (LKA0400-C□□□) (LKA0480-C□□□) (LKA0550-C□□□) | (LKC0400-C□□□) (LKC0480-C□□□) (LKC0550-C□□□) | LKE0300-C□ LKE0360-C□ LKE0400-C□ LKE0480-C□ LKE0550-C□ | (LKW0400-C□□□) (LKW0480-C□□□) (LKW0550-C□□□) | LM0360-C□ LM0400-C□ LM0480-C□ LM0550-C□ | (LL0360-C□□□) (LL0400-C□□□) (LL0480-C□□□) (LL0550-C□□□) | (LLR0360-C□□□□) (LLR0400-C□□□□) (LLR0480-C□□□□) (LLR0550-C□□□□) |
| BZL0100-B | / | LKA0360-C□□□ LKA0400-C□□□ LKA0480-C□□□ LKA0550-C□□□ | LKC0400-C□□□ LKC0480-C□□□ LKC0550-C□□□ | / | LKW0400-C□□□ LKW0480-C□□□ LKW0550-C□□□ | / | LL0360-C□□□ LL0400-C□□□ LL0480-C□□□ LL0550-C□□□ | LLR0360-C□□□□ LLR0400-C□□□□ LLR0480-C□□□□ LLR0550-C□□□□ |
| BZL0200-A | LT0650-C□ LT0750-C□ | (LKA0650-C□□□) (LKA0750-C□□□) | (LKC0650-C□□□) | / | (LKW0650-C□□□) | LM0650-C□ LM0750-C□ | (LL0650-C□□□) (LL0750-C□□□) | (LLR0650-C□□□□) (LLR0750-C□□□□) |
| BZL0200-B | / | LKA0650-C□□□ LKA0750-C□□□ | LKC0650-C□□□ | / | LKW0650-C□□□ | / | LL0650-C□□□ LL0750-C□□□ | LLR0650-C□□□□ LLR0750-C□□□□ |
| BZL0300-A | LG0900-C□ LG1050-C□ | (LKA0900-C□□□) (LKA1050-C□□□) | / | / | / | LJ0902-C□ LJ1052-C□ | (LL0900-C□□□) (LL1050-C□□□) | (LLR0900-C□□□□) (LLR1050-C□□□□) |
| BZL0300-B | / | LKA0900-C□□□ LKA1050-C□□□ | / | / | / | / | LL0900-C□□□ LL1050-C□□□ | LLR0900-C□□□□ LLR1050-C□□□□ |

| Model No. | LLW (Double Action) Lift Cylinder |
|-----------|--|
| BZL0100-A | (LLW0360-C□□□) (LLW0400-C□□□) (LLW0480-C□□□) |
| BZL0100-B | LLW0360-C□□□ LLW0400-C□□□ LLW0480-C□□□ |

- Note 1. Flow control circuit for double acting cylinder both should have meter-out circuits for the locking side and release side except model LKE/TLA/TMA.
Meter-in controls can be adversely affected by any air in the system.

High-Power Series

Pneumatic Series

Hydraulic Series

Valve / Coupler Hydraulic Unit

Manual Operation Accessories

Cautions / Others

Hole Clamp

SFA
SFC

Swing Clamp

LHA
LHC
LHS
LHW
LT/LG
TLA-2
TLB-2
TLA-1

Link Clamp

LKA
LKC
LKW
LM/LJ
TMA-2
TMA-1

Work Support

LD
LC
TNC
TC

Air Sensing Lift Cylinder

LLW

Compact Cylinder

LL
LLR
LLU
DP
DR
DS
DT

Block Cylinder

DBA
DBC

Control Valve

BZL
BZT
BZX/JZG

Pallet Clamp

VS
VT

Expansion Locating Pin

VL
VM
VJ
VK

Pull Stud Clamp

FP
FQ

Customized Spring Cylinder

DWA/DWB

● Flow Rate Graph < Hydraulic Fluids ISO-VG32 (25~35°C) >

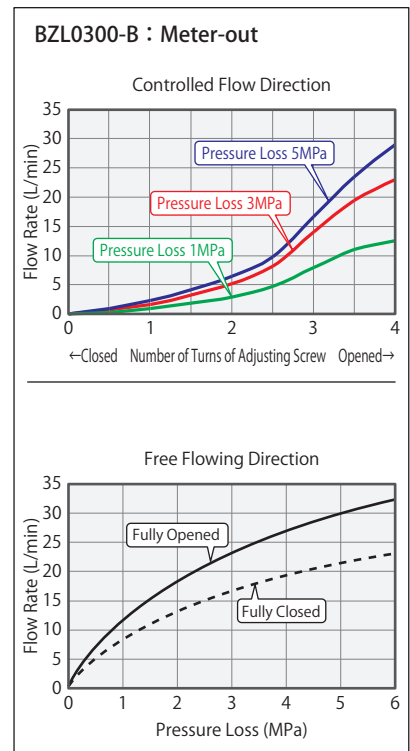
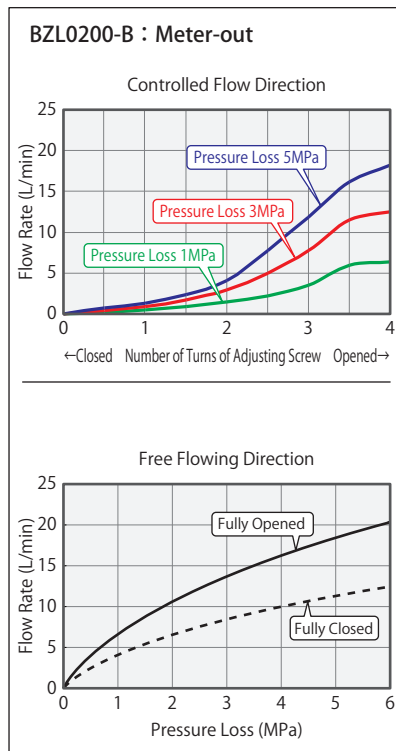
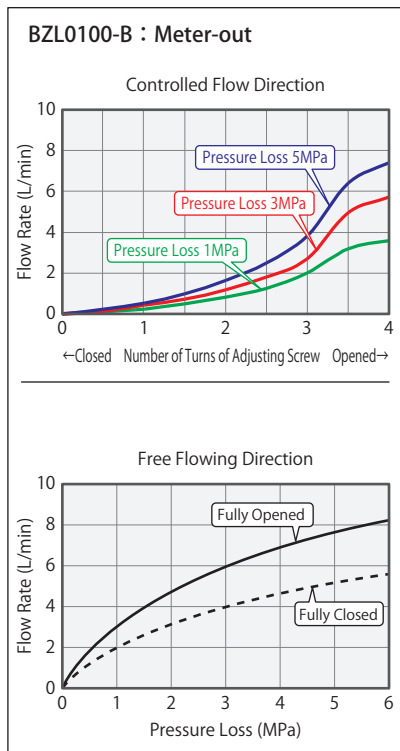
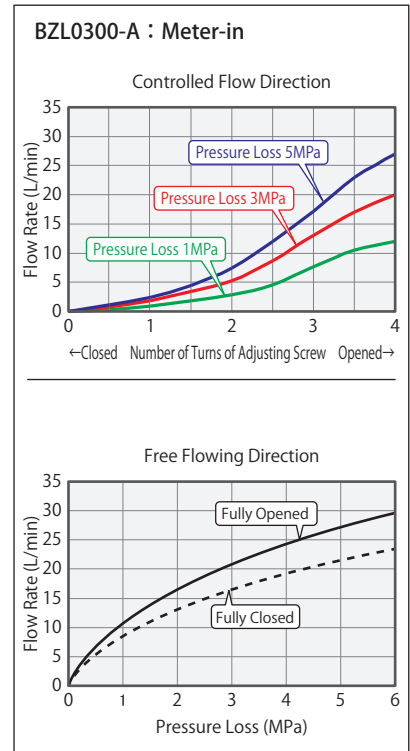
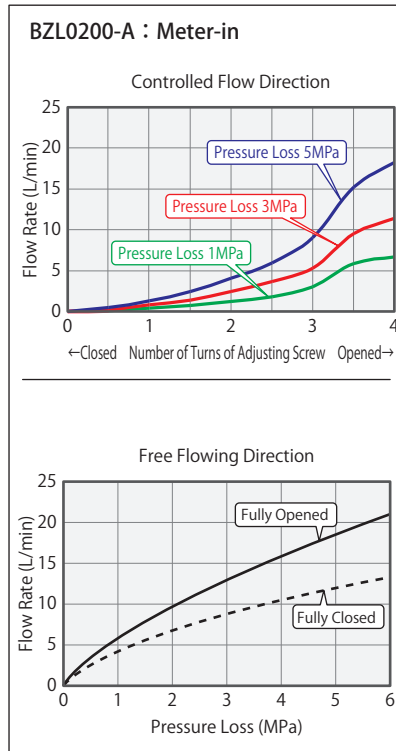
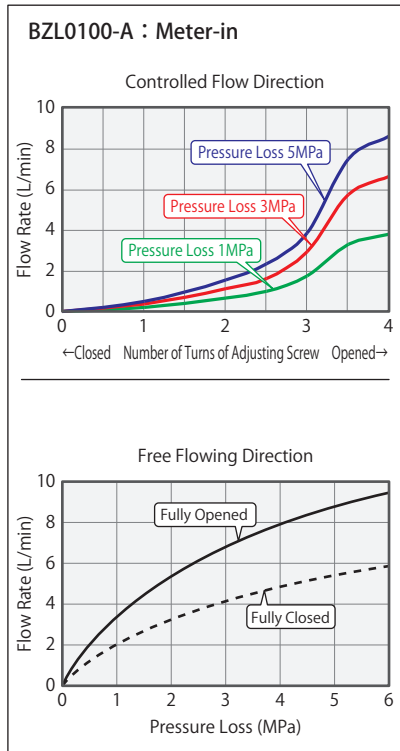

External Dimensions

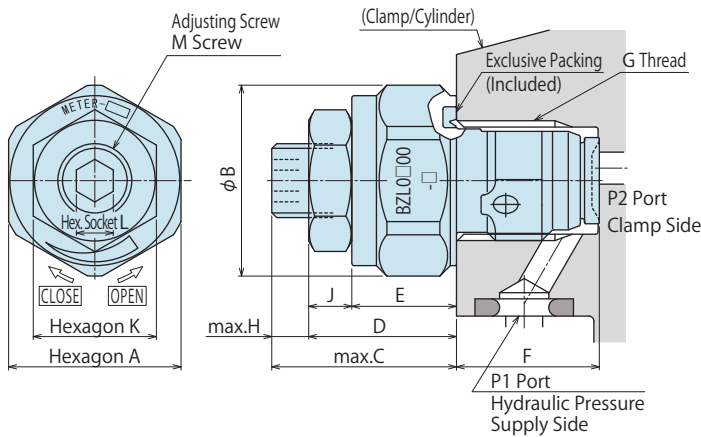

Machining Dimensions of Mounting Area

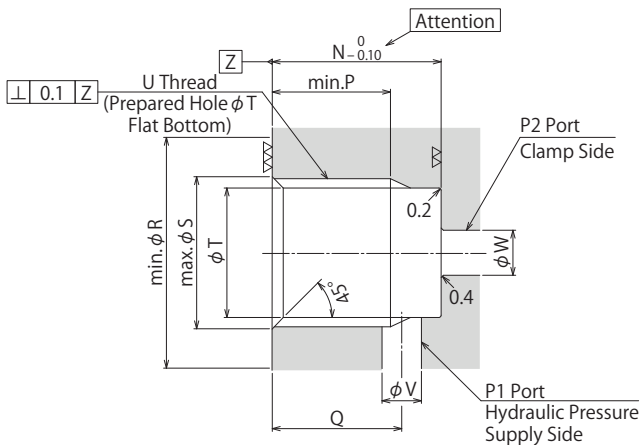

Notes

- Since the $\nabla\nabla$ area is sealing part, be careful not to damage it.
- Since the $\nabla\nabla$ area is the metal sealing part of BZL, be careful not to damage it. (Especially when deburring)
- No cutting chips or burr should be at the tolerance part of machining hole.
- As shown in the drawing, P1 port is used as the hydraulic supply and P2 port as the clamp side.
- If mounting plugs or fittings with G thread specification available in the market, the dimension '*1' should be 12.5.

Notes

- Please read "Notes on Hydraulic Cylinder Speed Control Circuit" to assist with proper hydraulic circuit design.
If there is something wrong with the circuit design, it leads to the applications malfunction and damage. (Refer to P.1044)
- It is dangerous to air bleed during operation under high pressure. It must be done under lower pressure.
(For reference: the minimum operating range of the product within the circuit.)

(mm)

| Model No. | BZL0100-□ | BZL0200-□ | BZL0300-□ |
|-----------------------|-----------|-----------|-----------|
| A | 14 | 18 | 22 |
| B | 15.5 | 20 | 24 |
| C | 15 | 16 | 19 |
| D | 12 | 13 | 16 |
| E | 8.5 | 9.5 | 11 |
| F | (11.6) | (15.1) | (17.6) |
| G | G1/8 | G1/4 | G3/8 |
| H | 3 | 3 | 3 |
| J | 3.5 | 3.5 | 5 |
| K | 10 | 10 | 13 |
| L | 3 | 3 | 4 |
| M | M6×0.75 | M6×0.75 | M8×0.75 |
| N | 11.5 | 15 | 17.5 |
| P | 8.5 | 11※1 | 13 |
| Q | 9 | 11.5 | 13 |
| R (Flat Surface Area) | 16 | 20.5 | 24.5 |
| S | 10 | 13.5 | 17 |
| T | 8.7 | 11.5 | 15 |
| U | G1/8 | G1/4 | G3/8 |
| V | 2 ~ 3 | 3 ~ 4 | 4 ~ 5 |
| W | 2.5 ~ 5 | 3.5 ~ 7 | 4.5 ~ 9 |

High-Power Series

Pneumatic Series

Hydraulic Series

Valve / Coupler Hydraulic Unit

Manual Operation Accessories

Cautions / Others

Hole Clamp

SFA
SFC

Swing Clamp

LHA
LHC
LHS
LHW
LT/LG
TLA-2
TLB-2
TLA-1

Link Clamp

LKA
LKC
LKW
LM/LJ
TMA-2
TMA-1

Work Support

LD
LC
TNC
TC

Air Sensing Lift Cylinder

LLW

Compact Cylinder

LL
LLR
LLU
DP
DR
DS
DT

Block Cylinder

DBA
DBC

Control Valve

BZL
BZT
BZX/JZG

Pallet Clamp

VS
VT

Expansion Locating Pin

VL
VM
VJ
VK

Pull Stud Clamp

FP
FQ

Customized Spring Cylinder

DWA/DWB

Model No. Indication (Air Bleed Valve)

BZX0 **1** **0**

1 **2**



1 G Thread Size

- 1 : Thread Part G1/8A Thread
- 2 : Thread Part G1/4A Thread
- 3 : Thread Part G3/8A Thread

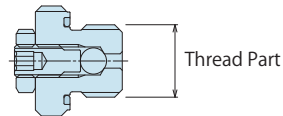

2 Design No.

- 0 : Revision Number

Specifications

| Model No. | BZX010 | BZX020 | BZX030 |
|-------------------------------------|---|--------|--------|
| Max. Operating Pressure MPa | 25 | | |
| Withstanding Pressure MPa | 37.5 | | |
| G Thread Size | G1/8A | G1/4A | G3/8A |
| Usable Fluid | General Hydraulic Oil Equivalent to ISO-VG-32 | | |
| Operating Temperature °C | 0 ~ 70 | | |
| Tightening Torque for Main Body N·m | 10 | 25 | 35 |

Circuit Symbol

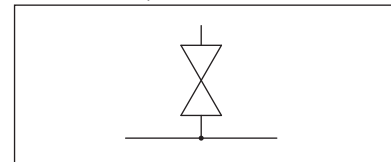

- Notes
- Do not over loosen the plug during air venting.
(Do not loosen for more than 2 turns from the fully closed position.)
 - It is dangerous to have air venting operation under high pressure. It must be done under lower pressure.
(For reference: the minimum operation pressure range of the product within the circuit)
 - Refer to the processing dimensions for BZL mounting area.

Applicable Products

| Model No. | DBA (Single Action) Block Cylinder | DBC (Single Action) Block Cylinder | LC (Single Action) Work Support | LHA (Double Action) Swing Clamp | LHC (Double Action) Swing Clamp | LHE (Double Action) High-Power Swing Clamp | LHS (Double Action) Swing Clamp | LHW (Double Action) Swing Clamp |
|-----------|---------------------------------------|---------------------------------------|--|--|--|--|--|--|
| BZX010 | DBA0250-C□ DBA0320-C□ | DBC0250-C□ DBC0320-C□ | LC0402-C□□□ LC0482-C□□□ LC0552-C□□□ LC0652-C□□□ | LHA0360-C□□□ LHA0400-C□□□ LHA0480-C□□□ LHA0550-C□□□ | LHC0360-C□□□ LHC0400-C□□□ LHC0480-C□□□ LHC0550-C□□□ | LHE0300-C□ LHE0360-C□ LHE0400-C□ LHE0480-C□ LHE0550-C□ | LHS0360-C□□□ LHS0400-C□□□ LHS0480-C□□□ LHS0550-C□□□ | LHW0400-C□□□ LHW0480-C□□□ LHW0550-C□□□ |
| BZX020 | DBA0400-C□ DBA0500-C□ | DBC0400-C□ DBC0500-C□ | LC0752-C□□□ LC0902-C□□□ | LHA0650-C□□□ LHA0750-C□□□ | LHC0650-C□□□ | | LHS0650-C□□□ LHS0750-C□□□ | LHW0650-C□□□ |
| BZX030 | | | | LHA0900-C□□□ LHA1050-C□□□ | | | LHS0900-C□□□ LHS1050-C□□□ | |

| Model No. | LT/LG (Single Action) Swing Clamp | LKA (Double Action) Link Clamp | LKC (Double Action) Link Clamp | LKE (Double Action) High-Power Link Clamp | LKW (Double Action) Link Clamp | LM/LJ (Single Action) Link Clamp | LL (Double Action) Linear Cylinder | LLR (Double Action) Linear Cylinder |
|-----------|--|--|--|--|--|--|--|--|
| BZX010 | LT0360-C□ LT0400-C□ LT0480-C□ LT0550-C□ | LKA0360-C□□□ LKA0400-C□□□ LKA0480-C□□□ LKA0550-C□□□ | LKC0400-C□□□ LKC0480-C□□□ LKC0550-C□□□ | LKE0300-C□ LKE0360-C□ LKE0400-C□ LKE0480-C□ LKE0550-C□ | LKW0400-C□□□ LKW0480-C□□□ LKW0550-C□□□ | LM0360-C□ LM0400-C□ LM0480-C□ LM0550-C□ | LL0360-C□□□ LL0400-C□□□ LL0480-C□□□ LL0550-C□□□ | LLR0360-C□□□□ LLR0400-C□□□□ LLR0480-C□□□□ LLR0550-C□□□□ |
| BZX020 | LT0650-C□ LT0750-C□ | LKA0650-C□□□ LKA0750-C□□□ | LKC0650-C□□□ | | LKW0650-C□□□ | LM0650-C□ LM0750-C□ | LL0650-C□□□ LL0750-C□□□ | LLR0650-C□□□□ LLR0750-C□□□□ |
| BZX030 | LG0900-C□ LG1050-C□ | LKA0900-C□□□ LKA1050-C□□□ | | | | LJ0902-C□ LJ1052-C□ | LL0900-C□□□ LL1050-C□□□ | LLR0900-C□□□□ LLR1050-C□□□□ |

| Model No. | LLW (Double Action) Lift Cylinder |
|-----------|--|
| BZX010 | LLW0360-C□□□ LLW0400-C□□□ LLW0480-C□□□ |

External Dimensions

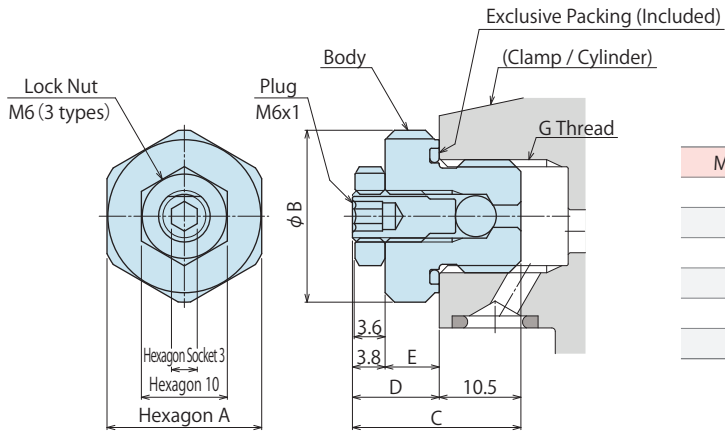

| Model No. | BZX010 | BZX020 | BZX030 |
|-----------|--------|--------|--------|
| A | 14 | 18 | 22 |
| B | 15.5 | 20 | 24 |
| C | 19.8 | 20.6 | 20.6 |
| D | 9.3 | 10.1 | 10.1 |
| E | 5.5 | 6.3 | 6.3 |
| G | G1/8 | G1/4 | G3/8 |

(mm)

High-Power
Series

Pneumatic Series

Hydraulic Series

Valve / Coupler
Hydraulic UnitManual Operation
Accessories

Cautions / Others

Hole Clamp

SFA
SFC

Swing Clamp

LHA
LHC
LHS
LHW
LT/LG
TLA-2
TLB-2
TLA-1

Link Clamp

LKA
LKC
LKW
LM/LJ
TMA-2
TMA-1

Work Support

LD
LC
TNC
TCAir Sensing
Lift Cylinder

LLW

Compact Cylinder

LL
LLR
LLU
DP
DR
DS
DT

Block Cylinder

DBA
DBC

Control Valve

BZL
BZT

BZX/JZG

Pallet Clamp

VS
VTExpansion
Locating PinVL
VM
VJ
VK

Pull Stud Clamp

FP
FQCustomized
Spring Cylinder

DWA/DWB

Model No. Indication (G Thread Plug with Air Bleeding Function)

JZG0 1 0

1 2



1 G Thread Size

- 1 : Thread Part G1/8A Thread
- 2 : Thread Part G1/4A Thread
- 3 : Thread Part G3/8A Thread

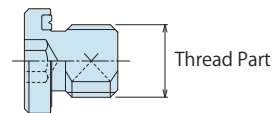

2 Design No.

- 0 : Revision Number

Specifications

| Model No. | JZG010 | JZG020 | JZG030 |
|-------------------------------------|---|--------|--------|
| Max. Operating Pressure MPa | 35 | | |
| Withstanding Pressure MPa | 42 | | |
| G Thread Size | G1/8A | G1/4A | G3/8A |
| Usable Fluid | General Hydraulic Oil Equivalent to ISO-VG-32 | | |
| Operating Temperature °C | 0 ~ 70 | | |
| Tightening Torque for Main Body N·m | 10 | 25 | 35 |

- Notes
- It is dangerous to have air venting operation under high pressure. It must be done under lower pressure.
(For reference: the minimum operation pressure range of the product within the circuit)
 - Refer to the processing dimensions for BZL mounting area.

Applicable Products

| Model No. | DBA (Single Action) Block Cylinder | DBC (Single Action) Block Cylinder | LC (Single Action) Work Support | LHA (Double Action) Swing Clamp | LHC (Double Action) Swing Clamp | LHE (Double Action) High-Power Swing Clamp | LHS (Double Action) Swing Clamp | LHW (Double Action) Swing Clamp |
|-----------|---------------------------------------|---------------------------------------|--|--|--|--|--|--|
| JZG010 | DBA0250-C□ DBA0320-C□ | DBC0250-C□ DBC0320-C□ | LC0402-C□□□ LC0482-C□□□ LC0552-C□□□ LC0652-C□□□ | LHA0360-C□□□ LHA0400-C□□□ LHA0480-C□□□ LHA0550-C□□□ | LHC0360-C□□□ LHC0400-C□□□ LHC0480-C□□□ LHC0550-C□□□ | LHE0300-C□ LHE0360-C□ LHE0400-C□ LHE0480-C□ LHE0550-C□ | LHS0360-C□□□ LHS0400-C□□□ LHS0480-C□□□ LHS0550-C□□□ | LHW0400-C□□□ LHW0480-C□□□ LHW0550-C□□□ |
| JZG020 | DBA0400-C□ DBA0500-C□ | DBC0400-C□ DBC0500-C□ | LC0752-C□□□ LC0902-C□□□ | LHA0650-C□□□ LHA0750-C□□□ | LHC0650-C□□□ | | LHS0650-C□□□ LHS0750-C□□□ | LHW0650-C□□□ |
| JZG030 | | | | LHA0900-C□□□ LHA1050-C□□□ | | | LHS0900-C□□□ LHS1050-C□□□ | |

| Model No. | LT/LG (Single Action) Swing Clamp | LKA (Double Action) Link Clamp | LKC (Double Action) Link Clamp | LKE (Double Action) High-Power Link Clamp | LKW (Double Action) Link Clamp | LM/LJ (Single Action) Link Clamp | LL (Double Action) Linear Cylinder | LLR (Double Action) Linear Cylinder |
|-----------|--|--|--|--|--|--|--|--|
| JZG010 | LT0360-C□ LT0400-C□ LT0480-C□ LT0550-C□ | LKA0360-C□□□ LKA0400-C□□□ LKA0480-C□□□ LKA0550-C□□□ | LKC0400-C□□□ LKC0480-C□□□ LKC0550-C□□□ | LKE0300-C□ LKE0360-C□ LKE0400-C□ LKE0480-C□ LKE0550-C□ | LKW0400-C□□□ LKW0480-C□□□ LKW0550-C□□□ | LM0360-C□ LM0400-C□ LM0480-C□ LM0550-C□ | LL0360-C□□□ LL0400-C□□□ LL0480-C□□□ LL0550-C□□□ | LLR0360-C□□□□□ LLR0400-C□□□□□ LLR0480-C□□□□□ LLR0550-C□□□□□ |
| JZG020 | LT0650-C□ LT0750-C□ | LKA0650-C□□□ LKA0750-C□□□ | LKC0650-C□□□ | | LKW0650-C□□□ | LM0650-C□ LM0750-C□ | LL0650-C□□□ LL0750-C□□□ | LLR0650-C□□□□□ LLR0750-C□□□□□ |
| JZG030 | LG0900-C□ LG1050-C□ | LKA0900-C□□□ LKA1050-C□□□ | | | | LJ0902-C□ LJ1052-C□ | LL0900-C□□□ LL1050-C□□□ | LLR0900-C□□□□□ LLR1050-C□□□□□ |

| Model No. | LLW (Double Action) Lift Cylinder | TLA-2 (Double Action) Swing Clamp | TLB-2 (Double Action) Swing Clamp | TLA-1 (Single Action) Swing Clamp | TMA-2 (Double Action) Link Clamp | TMA-1 (Single Action) Link Clamp |
|-----------|--|---|---|---|--|--|
| JZG010 | LLW0360-C□□□□□ LLW0400-C□□□□□ LLW0480-C□□□□□ | TLA0401-2C□□□ TLA0601-2C□□□ TLA0801-2C□□□ TLA1001-2C□□□ TLA1601-2C□□□ | TLB0401-2C□□□ TLB0601-2C□□□ TLB0801-2C□□□ TLB1001-2C□□□ TLB1601-2C□□□ | TLA0402-1C□ TLA0602-1C□ TLA0802-1C□ TLA1002-1C□ TLA1602-1C□ | TMA0250-2C□ TMA0400-2C□ TMA0600-2C□ TMA1000-2C□ | TMA0250-1C□ TMA0400-1C□ TMA0600-1C□ TMA1000-1C□ |
| JZG020 | | TLA2001-2C□□□ TLA2501-2C□□□ TLA4001-2C□□□ | TLB2001-2C□□□ TLB2501-2C□□□ TLB4001-2C□□□ | TLA2002-1C□ TLA2502-1C□ TLA4002-1C□ | TMA1600-2C□ TMA2500-2C□ TMA3200-2C□ | TMA1600-1C□ TMA2500-1C□ TMA3200-1C□ |

External Dimensions

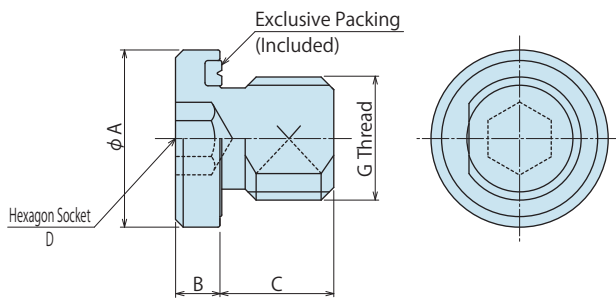

| Model No. | JZG010 | JZG020 | JZG030 |
|-----------|--------|--------|--------|
| A | 14 | 18 | 22 |
| B | 3.5 | 4.5 | 4.5 |
| C | 8 | 9 | 10 |
| D | 5 | 6 | 8 |
| G | G1/8A | G1/4A | G3/8A |

(mm)

High-Power Series

Pneumatic Series

Hydraulic Series

Valve / Coupler Hydraulic Unit

Manual Operation Accessories

Cautions / Others

Hole Clamp

SFA
SFC

Swing Clamp

LHA
LHC
LHS
LHW
LT/LG
TLA-2
TLB-2
TLA-1

Link Clamp

LKA
LKC
LKW
LM/LJ
TMA-2
TMA-1

Work Support

LD
LC
TNC
TC

Air Sensing Lift Cylinder

LLW

Compact Cylinder

LL
LLR
LLU
DP
DR
DS
DT

Block Cylinder

DBA
DBC

Control Valve

BZL
BZT

BZX/JZG

Pallet Clamp

VS
VT

Expansion Locating Pin

VL
VM
VJ
VK

Pull Stud Clamp

FP
FQ

Customized Spring Cylinder

DWA/DWB

Manifold Block

Model WHZ-MD

Model LZY-MD

Model LZ-MS

Model LZ-MP

Model TMZ-1MB

Model TMZ-2MB

Model DZ-MG

Model DZ-MS

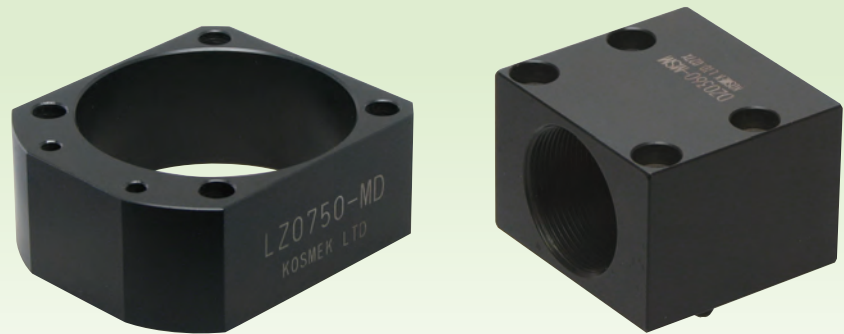

- **Manifold Block**

The mounting height of clamp is adjustable with the manifold block.

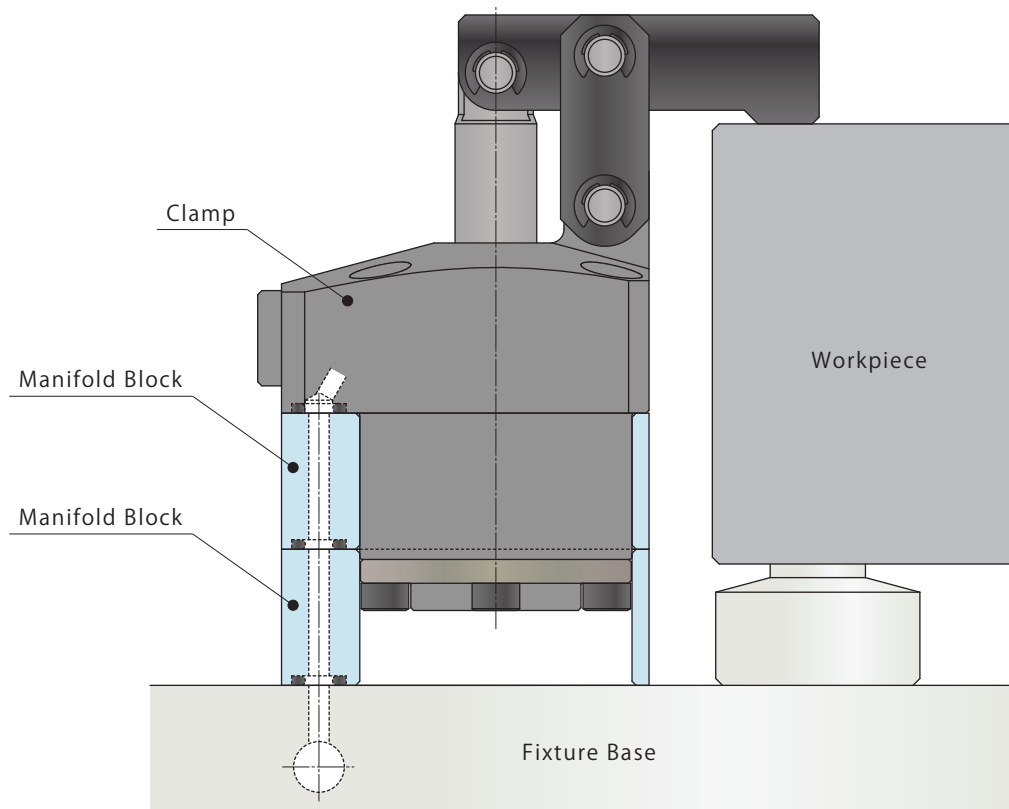

Applicable Model

| Manifold Block Model No. | Corresponding Item Model No. |
|--------------------------|---|
| Model WHZ-MD | Model WCA Model WHA Model WCE Model WHE |
| Model LZY-MD | Model LKA Model LKE Model LHC Model LHS Model LKC Model LHA Model LHE Model LL |
| Model LZ-MS | Model LM Model LT Model LJ Model LG |
| Model LZ-MP | Model LC Model TC |
| Model TMZ-1MB | Model TMA-1 |
| Model TMZ-2MB | Model TMA-2 |
| Model DZ-MG□/MS□ | Model DP |

- High-Power Series
- Pneumatic Series
- Hydraulic Series
- Valve / Coupler Hydraulic Unit
- Manual Operation Accessories**
- Cautions / Others

- Screw Locator
- VXF

- Manual Expansion Locating Pin
- VX

- Manifold Block**
- WHZ-MD
- LZY-MD
- LZ-MS
- LZ-MP
- TMZ-1MB
- TMZ-2MB
- DZ-M

- Manifold Block / Nut
- DZ-R
- DZ-C
- DZ-P
- DZ-B
- LZ-S
- LZ-SQ
- TNZ-S
- TNZ-SQ

- Pressure Switch
- JB

- Pressure Gauge
- JGA/JGB

- Manifold
- JX

- Coupler Switch
- PS

- G-Thread Fitting

Application Examples

• Work Support (LC) Application Example

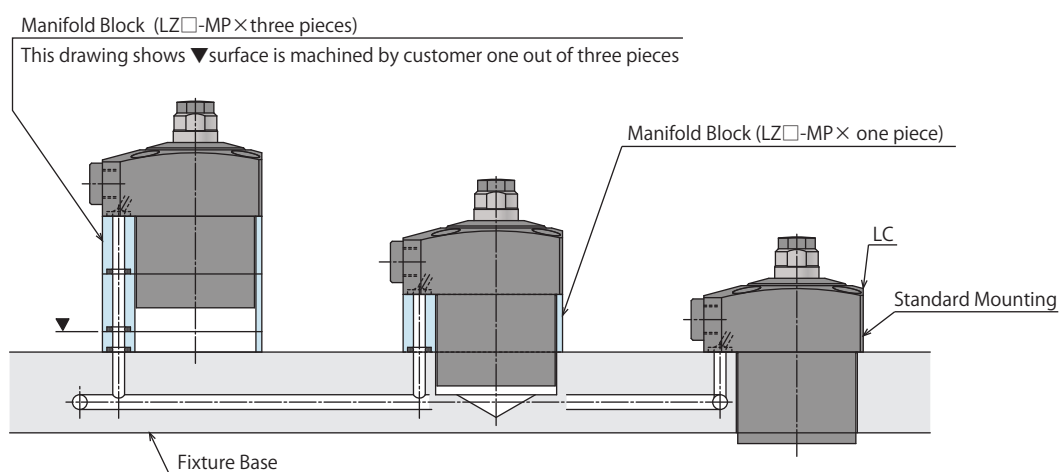

• Push Cylinder (DP) Application Example

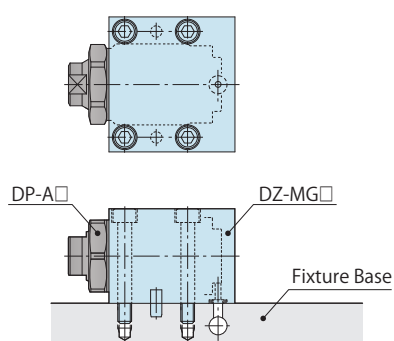

Manifold Block for WCA/WCE/WHA/WHE

Model No. Indication

WHZ 048 0 - MD

Size
(Refer to following table)

Design No.
(Revision Number)

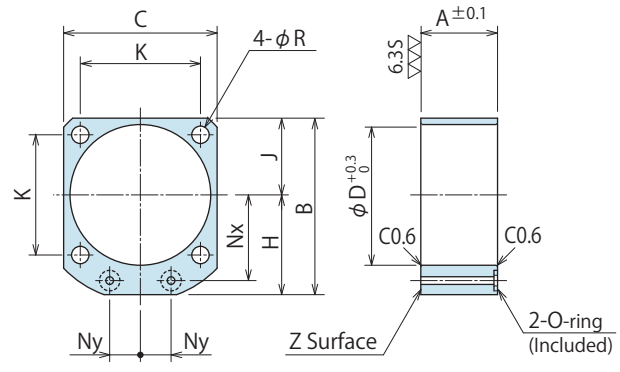

(mm)

| Model No. | WHZ0600-MD | WHZ0320-MD | WHZ0400-MD | WHZ0500-MD | WHZ0630-MD |
|---------------------------------|--------------------|--------------------|--------------------|--------------------|--------------------|
| Corresponding Item Model Number | WCE0601 WHE0600 | WCA0321 WHA0320 | WCE1001 WHE1000 | WCA0401 WHA0400 | WCE1601 WHE1600 |
| A | 23 | 25 | 27 | 31 | 35 |
| B | 54 | 60 | 67 | 77 | 88.5 |
| C | 45 | 50 | 58 | 68 | 81 |
| D | 40 | 46 | 54 | 64 | 77 |
| H | 31.5 | 35 | 38 | 43 | 48 |
| J | 22.5 | 25 | 29 | 34 | 40.5 |
| K | 34 | 39 | 45 | 53 | 65 |
| Nx | 26 | 28 | 31 | 36 | 41 |
| Ny | 9 | 10 | 13 | 15 | 20 |
| R | 5.5 | 5.5 | 5.5 | 6.5 | 6.5 |
| O-ring | 1BP5 | 1BP7 | 1BP7 | 1BP7 | 1BP7 |
| Mass kg | 0.1 | 0.1 | 0.1 | 0.2 | 0.2 |

- Notes
1. Material: A2017BE-T4
 2. Mounting bolts are not provided. Prepare mounting bolts according to the mounting height using the A dimensions as a reference.
 3. If thickness other than A is required, perform additional machining on surface Z. Please refer to the drawing.

Manifold Block for LKA/LKC/LKE/LHA/LHC/LHE/LHS/LL

Model No. Indication

LZY 048 0 - MD

Size
(Refer to following table)

Design No.
(Revision Number)

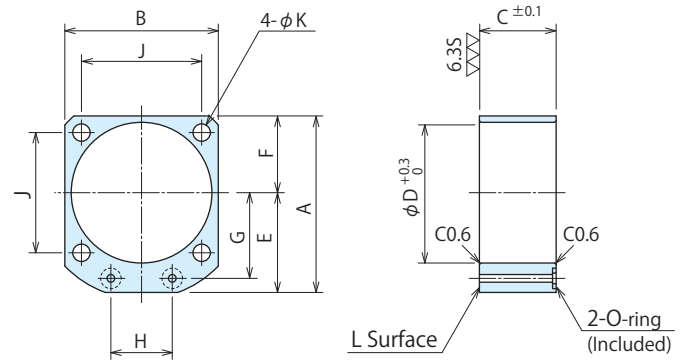

(mm)

| Model No. | LZY0360-MD | LZY0400-MD | LZY0480-MD | LZY0550-MD | LZY0650-MD | LZY0750-MD | LZY0900-MD | LZY1050-MD |
|---------------------------------|---|---|---|---|---|---|---|--|
| Corresponding Item Model Number | LKA0360 / LKE0360 LHA0360 / LHC0360 LHE0360 / LHS0360 LLO360 | LKA0400 / LKC0400 LKE0400 / LHA0400 LHC0400 / LHE0400 LHS0400 / LLO400 | LKA0480 / LKC0480 LKE0480 / LHA0480 LHC0480 / LHE0480 LHS0480 / LLO480 | LKA0550 / LKC0550 LKE0550 / LHA0550 LHC0550 / LHE0550 LHS0550 / LLO550 | LKA0650 / LKC0650 LHA0650 / LHC0650 LHS0650 LLO650 | LKA0750 LHA0750 LHS0750 LLO750 | LKA0900 LHA0900 LHS0900 LLO900 | LKA1050 LHA1050 LHS1050 LLO1050 |
| A | 49 | 54 | 61 | 69 | 81 | 92 | 107 | 122 |
| B | 40 | 45 | 51 | 60 | 70 | 80 | 95 | 110 |
| C | 20 | 20 | 27 | 30 | 32 | 37 | 45 | 50 |
| D | 36 | 40 | 48 | 55 | 65 | 75 | 90 | 105 |
| E | 29 | 31.5 | 35.5 | 39 | 46 | 52 | 59.5 | 67 |
| F | 20 | 22.5 | 25.5 | 30 | 35 | 40 | 47.5 | 55 |
| G | 23.5 | 26 | 30 | 33.5 | 39.5 | 45 | 52.5 | 60 |
| H | 16 | 18 | 22 | 24 | 30 | 32 | 37 | 45 |
| J | 31.4 | 34 | 40 | 47 | 55 | 63 | 75 | 88 |
| K | 4.5 | 5.5 | 5.5 | 6.8 | 6.8 | 9 | 11 | 14 |
| O-ring | 1BP5 | 1BP5 | 1BP5 | 1BP5 | 1BP7 | 1BP7 | 1BP7 | 1BP7 |
| Mass kg | 0.2 | 0.2 | 0.3 | 0.4 | 0.5 | 0.8 | 1.2 | 1.7 |

- Notes
1. Material: S45C
 2. Mounting bolts are not provided. Prepare mounting bolts according to the mounting height using the C dimensions as a reference.
 3. If thickness other than C is required, perform additional machining on surface L. Please refer to the drawing.

Manifold Block for LM/LJ/LT/LG

Model No. Indication

LZ 048 0 - MS

Size
(Refer to following table)

Design No.
(Revision Number)

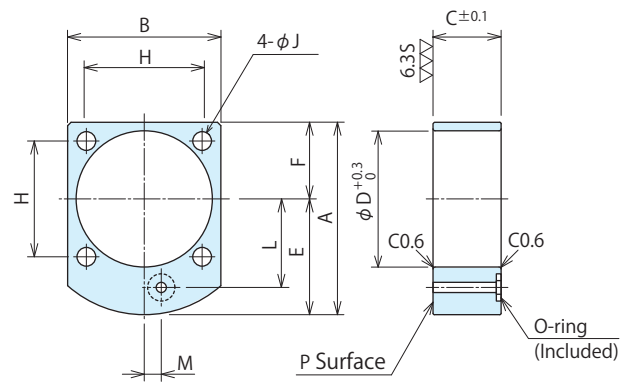

(mm)

| Model No. | LZ0360-MS | LZ0400-MS | LZ0480-MS | LZ0550-MS | LZ0650-MS | LZ0750-MS | LZ0900-MS | LZ1050-MS |
|--------------------|-----------|-----------|-----------|-----------|-----------|-----------|-----------|-----------|
| Corresponding Item | LT0360 | LT0400 | LT0480 | LT0550 | LT0650 | LT0750 | LG0900 | LG1050 |
| Model Number | LM0360 | LM0400 | LM0480 | LM0550 | LM0650 | LM0750 | LJ0902 | LJ1052 |
| A | 51.5 | 56.5 | 62 | 70 | 82 | 93 | 107 | 122 |
| B | 40 | 45 | 51 | 60 | 70 | 80 | 95 | 110 |
| C | 20 | 20 | 27 | 30 | 32 | 37 | 45 | 50 |
| D | 36 | 40 | 48 | 55 | 65 | 75 | 90 | 105 |
| E | 31.5 | 34 | 36.5 | 40 | 47 | 53 | 59.5 | 67 |
| F | 20 | 22.5 | 25.5 | 30 | 35 | 40 | 47.5 | 55 |
| H | 31.4 | 34 | 40 | 47 | 55 | 63 | 75 | 88 |
| J | 4.5 | 5.5 | 5.5 | 6.8 | 6.8 | 9 | 11 | 14 |
| L | 23.5 | 26 | 30 | 33.5 | 39.5 | 45 | 52.5 | 60 |
| M | 5 | 5 | 0 | 0 | 0 | 0 | 0 | 0 |
| O-ring | 1BP5 | 1BP5 | 1BP5 | 1BP5 | 1BP7 | 1BP7 | 1BP7 | 1BP7 |
| Mass kg | 0.2 | 0.2 | 0.3 | 0.4 | 0.5 | 0.8 | 1.2 | 1.7 |

- Notes
1. Material: S45C
 2. Mounting bolts are not provided. Prepare mounting bolts according to the mounting height using the C dimensions as a reference.
 3. If thickness other than C is required, perform additional machining on surface L. Please refer to the drawing.

Manifold Block for LC/TC

Model No. Indication

LZ 048 0 - MP

Size
(Refer to following table)

Design No.
(Revision Number)

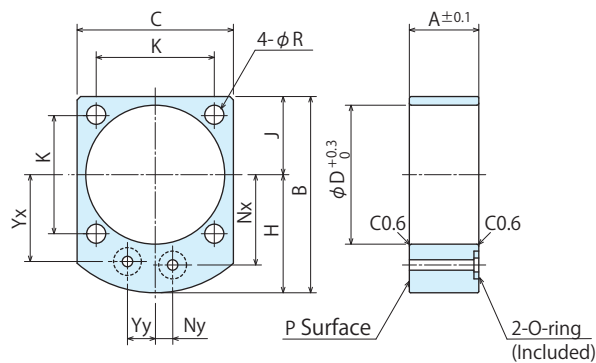

(mm)

| Model No. | LZ0400-MP | LZ0480-MP | LZ0550-MP | LZ0650-MP | LZ0750-MP | LZ0900-MP |
|--------------------|-----------|-----------|-----------|-----------|-----------|-----------|
| Corresponding Item | LC0402 | LC0482 | LC0552 | LC0652 | LC0752 | LC0902 |
| Model Number | TC0402 | TC0482 | TC0552 | TC0652 | TC0752 | |
| A | 20 | 27 | 30 | 32 | 37 | 45 |
| B | 56.5 | 62 | 70 | 82 | 93 | 107 |
| C | 45 | 51 | 60 | 70 | 80 | 95 |
| D | 40 | 48 | 55 | 65 | 75 | 90 |
| H | 34 | 36.5 | 40 | 47 | 53 | 59.5 |
| J | 22.5 | 25.5 | 30 | 35 | 40 | 47.5 |
| K | 34 | 40 | 47 | 55 | 63 | 75 |
| Nx | 26 | 30 | 33.5 | 39.5 | 45 | 52.5 |
| Ny | 5 | 0 | 0 | 0 | 0 | 0 |
| R | 5.5 | 5.5 | 6.8 | 6.8 | 9 | 11 |
| Yx | 25 | 28 | 31 | 37 | 42.5 | 50 |
| Yy | 8 | 11 | 13 | 14 | 15 | 15 |
| O-ring | 1BP5 | 1BP5 | 1BP5 | 1BP7 | 1BP7 | 1BP7 |
| Mass kg | 0.2 | 0.3 | 0.4 | 0.5 | 0.8 | 1.2 |

- Notes
1. Material: S45C
 2. Mounting bolts are not provided. Prepare mounting bolts according to the mounting height using the A dimensions as a reference.
 3. If thickness other than A is required, perform additional machining on surface P. Please refer to the drawing.

- High-Power Series
- Pneumatic Series
- Hydraulic Series
- Valve / Coupler Hydraulic Unit
- Manual Operation Accessories
- Cautions / Others
- Screw Locator
 - VXF
- Manual Expansion Locating Pin
 - VX
- Manifold Block
 - WHZ-MD
 - LZY-MD
 - LZ-MS
 - LZ-MP
 - TMZ-1MB
 - TMZ-2MB
 - DZ-M
- Manifold Block / Nut
 - DZ-R
 - DZ-C
 - DZ-P
 - DZ-B
 - LZ-S
 - LZ-SQ
 - TNZ-S
 - TNZ-SQ
- Pressure Switch
 - JB
- Pressure Gauge
 - JGA/JGB
- Manifold
 - JX
- Coupler Switch
 - PS
- G-Thread Fitting

Sales Offices

Sales Offices across the World

| | | |
|--|---|-------------------------------|
| Japan | TEL. +81-78-991-5162 | FAX. +81-78-991-8787 |
| Overseas Sales | KOSMEK LTD. 1-5, 2-chome, Murotani, Nishi-ku, Kobe-city, Hyogo, Japan 651-2241 〒651-2241 兵庫県神戸市西区室谷2丁目1番5号 | |
| USA | TEL. +1-630-241-3465 | FAX. +1-630-241-3834 |
| KOSMEK (USA) LTD. | 1441 Branding Avenue, Suite 110, Downers Grove, IL 60515 USA | |
| China | TEL.+86-21-54253000 | FAX.+86-21-54253709 |
| KOSMEK (CHINA) LTD. 考世美(上海)貿易有限公司 | 21/F, Orient International Technology Building, No.58, Xiangchen Rd, Pudong Shanghai 200122., P.R.China 中国上海市浦东新区向城路58号东方国际科技大厦21F室 200122 | |
| Thailand | TEL. +66-2-715-3450 | FAX. +66-2-715-3453 |
| Thailand Representative Office | 67 Soi 58, RAMA 9 Rd., Suanluang, Suanluang, Bangkok 10250, Thailand | |
| Taiwan (Taiwan Exclusive Distributor) | TEL. +886-2-82261860 | FAX. +886-2-82261890 |
| Full Life Trading Co., Ltd. 盈生貿易有限公司 | 16F-4, No.2, Jian Ba Rd., Zhonghe District, New Taipei City Taiwan 23511 台湾新北市中和區建八路2號 16F-4 (遠東世紀廣場) | |
| Philippines (Philippines Exclusive Distributor) | TEL.+63-2-310-7286 | FAX. +63-2-310-7286 |
| G.E.T. Inc, Phil. | Victoria Wave Special Economic Zone Mt. Apo Building, Brgy. 186, North Caloocan City, Metro Manila, Philippines 1427 | |
| Europe (Europe Exclusive Distributor) | TEL. +43-463-287587-10 | FAX. +43-463-287587-20 |
| KOS-MECH GmbH | Schleppeplatz 2 9020 Klagenfurt Austria | |
| Indonesia (Indonesia Exclusive Distributor) | TEL. +62-21-5818632 | FAX. +62-21-5814857 |
| P.T PANDU HYDRO PNEUMATICS | Ruko Green Garden Blok Z- II No.51 Rt.005 Rw.008 Kedoya Utara-Kebon Jeruk Jakarta Barat 11520 Indonesia | |

Sales Offices in Japan

| | | |
|----------------------|-----------------------------------|-------------------------|
| Head Office | TEL.078-991-5115 | FAX.078-991-8787 |
| Osaka Sales Office | 〒651-2241 兵庫県神戸市西区室谷2丁目1番5号 | |
| Overseas Sales | | |
| Tokyo Sales Office | TEL.048-652-8839 | FAX.048-652-8828 |
| | 〒331-0815 埼玉県さいたま市北区大成町4丁目81番地 | |
| Nagoya Sales Office | TEL.0566-74-8778 | FAX.0566-74-8808 |
| | 〒446-0076 愛知県安城市美園町2丁目10番地1 | |
| Fukuoka Sales Office | TEL.092-433-0424 | FAX.092-433-0426 |
| | 〒812-0006 福岡県福岡市博多区上牟田1丁目8-10-101 | |

Global Network

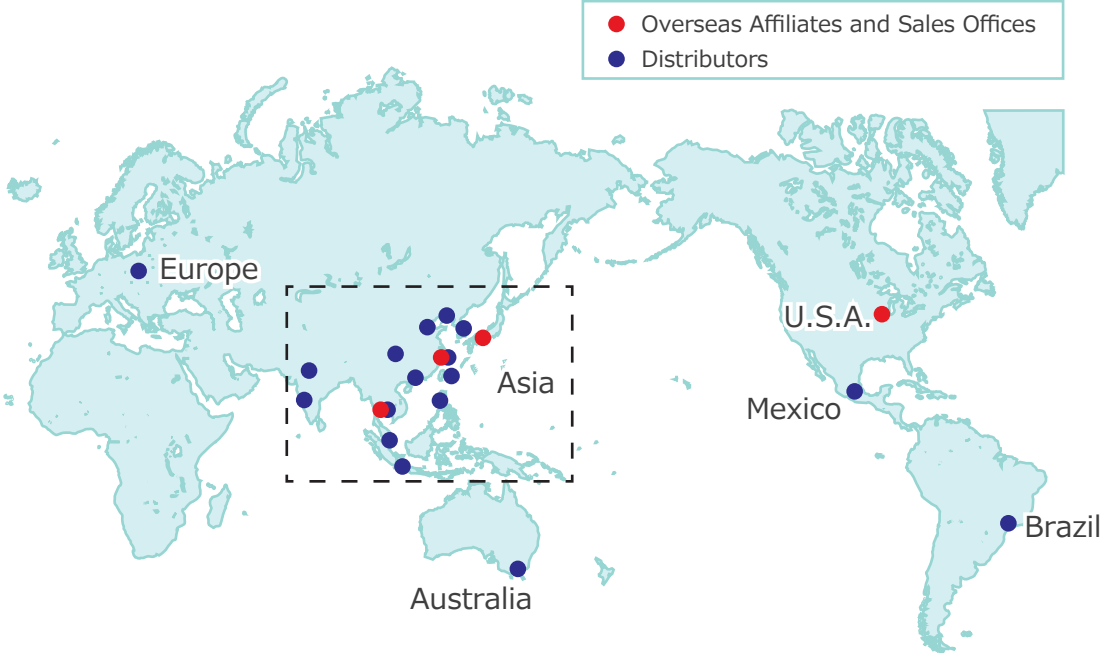

Asia Detailed Map



● FOR FURTHER INFORMATION ON UNLISTED SPECIFICATIONS AND SIZES, PLEASE CALL US.
● SPECIFICATIONS IN THIS CATALOG ARE SUBJECT TO CHANGE WITHOUT NOTICE.

